

Si-100 Motor Control



Features

- Programmable for stand alone operation with Applied Motion's easy to use *Si Programmer™* Windows software (software and programming cable included)
- Can be operated in real time from a host PC or PLC using Applied Motion's *Si Command Language™ (SCL)*
- Can be networked with all other *Si™* products via Applied Motion's *SiNet™* Hub
- 110 or 220 AC input, switch selectable
- 25 VDC and 5 VDC output voltages
- 8 optically isolated, 5–24 VDC, user programmable inputs
- 3 optically isolated, 24 VDC, outputs
- High speed, differential step & direction outputs interface easily to step and servo motor drives
- Communication via RS232
- Screw terminal connector blocks for power and I/O
- RJ11 for RS232 port
- Optional operator terminal (MMI) either standard or backlit
- Eight Applied Motion recommended pulse and direction Stepper drives and two pulse and direction Servo amplifiers
- CE and TUV compliant

Description

The Si-100 is a programmable motor control suitable for a wide range of motion control applications. It includes Applied Motion's easy to use

Si Programmer™ Windows software for the rapid development of stand-alone motion control programs. The Si-100 can also be commanded in real time from a host PC or PLC, using the *Si Command Language™ (SCL)*.

For multi-axis applications, up to eight Applied Motion *Si™* products (Stepper or Servo) can be networked using the *SiNet™* Hub, fulfilling the exact requirements of your application.

The Si-100 includes 8 optically isolated programmable inputs for triggering, branching, position sensing and end of travel detection. 3 optically isolated programmable outputs can send signals to other electronic devices and activate relays. High speed, differential step & direction outputs are provided for easy interfacing to industry popular step and servo motor drives.

Recommended drives for the Si-100:

Stepper	Servo
1030	BL7080X
1030D	BLX7080
2035	
2035XD	
3535	
3540M	
5560	
7080	
PDO 2035	
PDO 3540	

Si-100 Technical Specifications

AC INPUT POWER	110 or 220 VAC (switch selectable), 50–60 Hz.
MOTOR RESOLUTION	16 resolutions. Steps per revolution with 1.8° motor: 200, 400, 1000, 2000, 5000, 10000, 12800, 18000, 20000, 21600, 25000, 25400, 25600, 36000, 50000, 50800.
STEP AND DIRECTION OUTPUTS	2 sourcing outputs (step+ and dir+) and 2 sinking outputs (step– and dir–). Step+ and dir+ are 2.5min., 3.4V typ. with a 20na load. Step– and dir– are 8.5V max., 0.3V typ. with a 20ma load. The step frequency is 50Hz to 2.54MHz. The step duty cycle is 50% and the step rate is updated at 12,800Hz.
POWER SUPPLY OUTPUTS	5 and 24 VDC., 100ma max. The 24 VDC supply is isolated from the internal circuitry. The 5 VDC supply is not. Each supply is protected by a self resetting fuse.
SERIAL COMMUNICATION	RS-232 programming port.
STATUS LED'S	Two color, normal (green), limit (red).
INPUTS	8 inputs, 5–24 VDC, bidirectional, optically isolated. 2 dedicated limit switch inputs. 4 dedicated general purpose inputs (for triggering, sensing & program branching). 2 JOG inputs (cw and ccw) can be also used as general purpose inputs.
OUTPUTS	3 general purpose, optically isolated outputs for interfacing to other equipment. Can be set to a high or low voltage or programmed to send a pulse by the <i>Set Output</i> instruction.
PARAMETER RANGES	Distance: 1 to 16,000,000 steps. Speed: .025 to 50 revolutions per second (in any microstep resolution). Acceleration: 1 to 3,000 rev/sec/sec. Deceleration: 1 to 3,000 rev/sec/sec (set independently from acceleration). Time Delays: .01 to 300 seconds. Output Pulse Widths: 2 to 500 milliseconds. Iterations per loop: 1 to 65,535.
OPTIONAL OPERATOR INTERFACE (MMI)	NEMA 4X rated (splash proof & dust proof). 4 x 20 characters liquid crystal display (LCD). 20 key membrane keypad. Overall size: 4.9 x 4.9 x 1.42 inches.

SYSTEM SPECIFICATIONS:

OVERALL SIZE	1.25 x 3.86 x 8 inches. See mechanical outline.
CASE MATERIAL	Steel, finished with black textured paint and white silk screen.
WEIGHT	2 lbs.
AMBIENT TEMPERATURE	0° to 50°C (32° to 122°F).
HUMIDITY	Maximum of 90% non-condensing.
CONNECTORS	Screw terminal connectors for input power and I/O signals.
DRIVES	Indexer for step and direction compatible stepper and brushless DC drives.

Si-100 Technical Drawings

MECHANICAL OUTLINE:

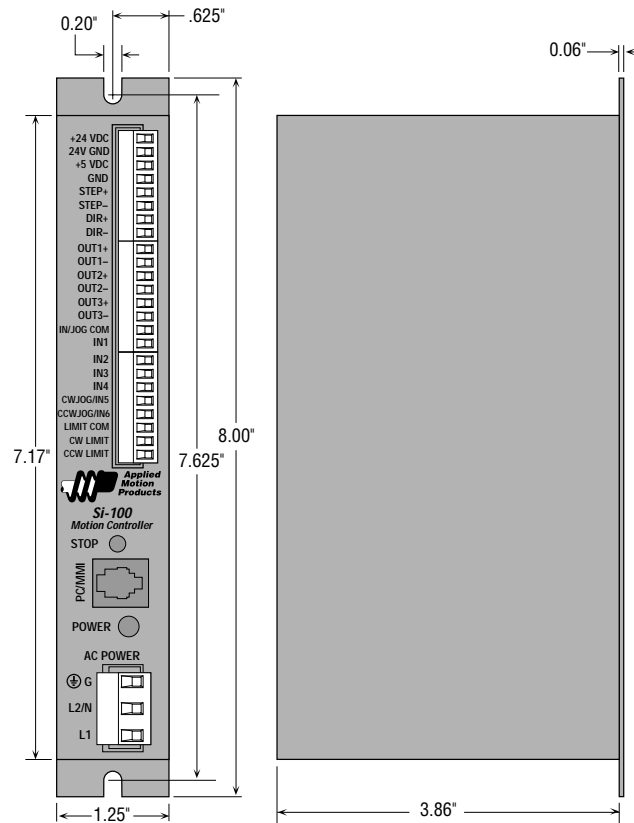

BLOCK DIAGRAM:

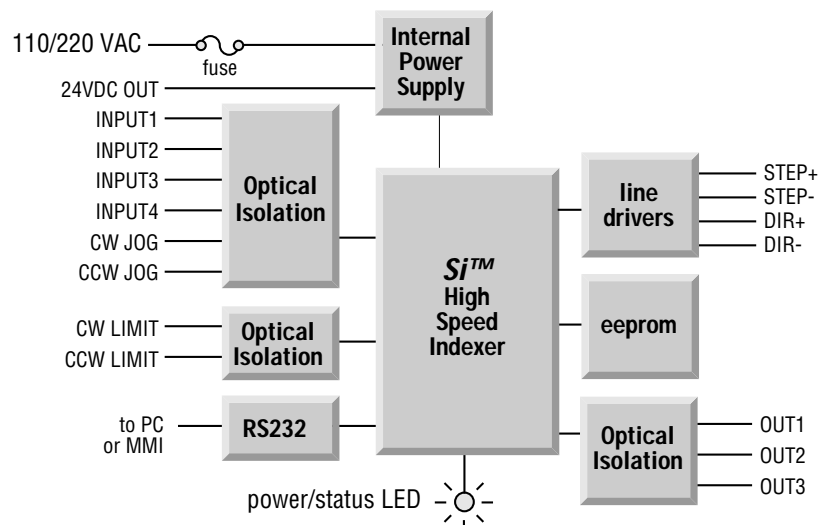

Si-100 Connectors and Switches

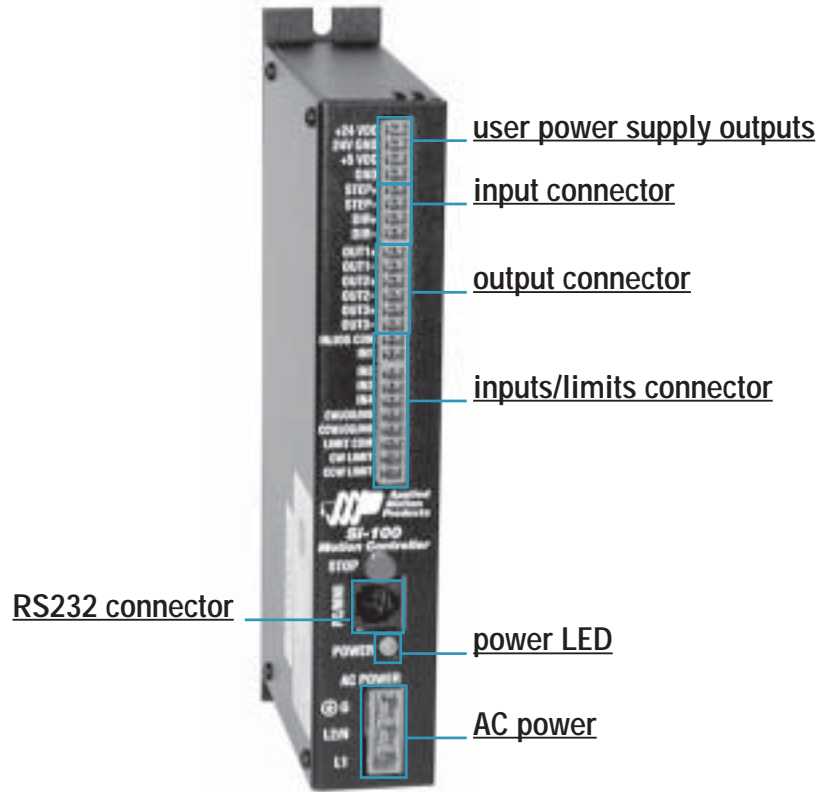

USER POWER OUTPUTS

position no.	
1	+24 VDC
2	24 V GND
3	+5 VDC
4	GND

I/O

position no.	
1	step+
2	step-
3	dir+
4	dir-
5	out 1+
6	out 1-
7	out 2+
8	out 2-
9	out 3+
10	out 3-
11	in/jog com
12	in 1
13	in 2
14	in 3
15	in 4
16	cw jog/in 5
17	ccw jog/in 6
18	limit com
19	cw limit
20	ccw limit

AC POWER

position no.	
1	G
2	L2/N
3	L1