

FB-EM-30346-000
SHT 1.1

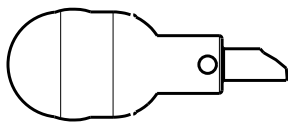

TOP VIEW
W/WINDSHIELD SHOWN
SCALE 1:1

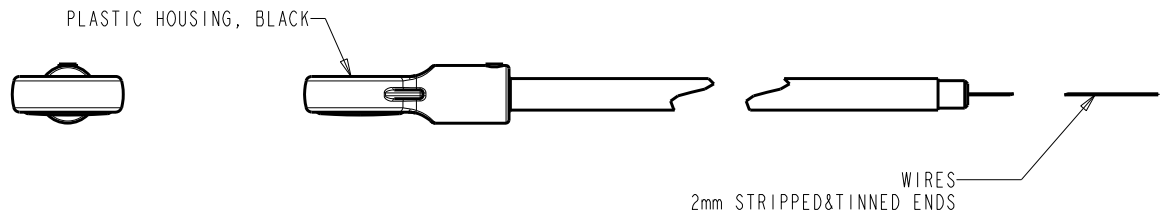
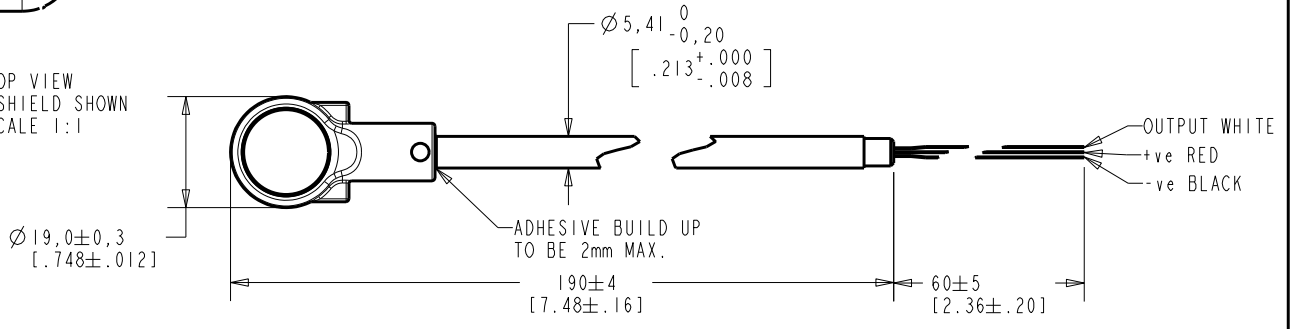

WIRE COLOR			WEIGHT GRAMS
+ve	OUTPUT	-ve	
RED	WHITE	BLACK	---

DIMENSIONS IN MILLIMETERS [INCHES]

Revision	C.O. #	Implementation Date	RELEASE LEVEL	REVISION
C	C40100518	11-24-10	Active	C
B	C10107748	8-12-08		
A	C10107379	6-26-08		

KNOWLES ELECTRONICS
ITASCA, ILLINOIS U.S.A.

SCALE:	1:1	DR. BY	DATE
DO NOT SCALE DRAWING		TT	6-26-08
TITLE:	BOOM MICROPHONE	CK. BY	DATE
	FB-EM-30346-000	GJP	7-15-08
	OUTLINE DRAWING	APP. BY	DATE
	SHT 1.1	GJP	7-15-08

HE111ASIZE.FRM Rev: B

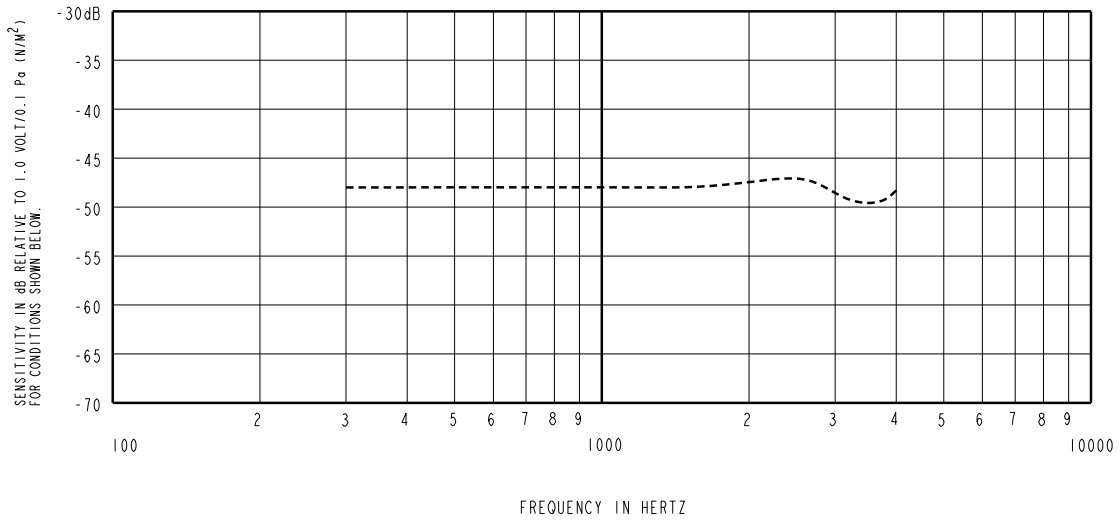

FREQUENCY	SENSITIVITY			DEVICE CONFORMITY	
	MIN.	NOM.	MAX.	RANGE OF DEVIATION FROM 1KHz	
300	---	-48.0	---	-3.0	+3.0
1000	-51.0	-48.0	-45.0	0.0	0.0
4000	---	-47.0	---	-3.0	+5.0

NOTES:

- MICROPHONE TO BE FUNCTIONAL WITH 10 VDC SUPPLY.
- SENSITIVITY VALUES INDICATED ON THIS SPECIFICATION ARE VALID AT 50% HUMIDITY.
- TEST CONDITIONS:
HEAD OF BOOM EXPOSED TO 74 dBSPL SWEPT SOUND FIELD AT 6mm FROM VOICE APERTURE.
ARTIFICIAL VOICE:
B & k 4227 MOUTH SIMULATOR.
- FOR MICROPHONE CAPSULE SPEC. SEE DRAWING EK-23132-C36 SHEET 2.1.
- SURVIVES SUBMERSION IN 1m OF WATER FOR 30 MINUTES; SENSITIVITY WITHIN 3dB OF INITIAL SENSITIVITY AFTER DRIED FOR 30 MINUTES AT ROOM TEMPERATURE.

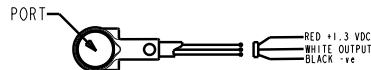
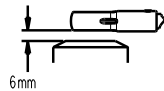

LEAD IDENTIFICATION & TEST CIRCUIT

Revision	C.O. #	Implementation Date	RELEASE LEVEL	REVISION
C	C40100518	11-24-10	Active	C
B	C10107748	8-12-08		
A	C10107379	6-26-08		

KNOWLES ELECTRONICS
ITASCA, ILLINOIS U.S.A.

WHEN TEST LIMITS ARE USED TO ESTABLISH INCOMING INSPECTION ACCEPTANCE/REJECTION CRITERIA, CORRELATION OF TEST EQUIPMENT WITH KNOWLES IS ALSO REQUIRED FOR ELIMINATION OF EQUIPMENT AND TEST METHOD VARIATION

DR. BY: TT DATE: 6-26-08

TITLE: **BOOM MICROPHONE** FB-EM-30346-000
PERFORMANCE SPECIFICATION SHT 2.1

CK. BY: GJP DATE: 7-15-08
APP. BY: GJP DATE: 7-15-08