

THIS DOCUMENT CONTAINS DATA PROPRIETARY TO PROJECTS UNLIMITED, INC. ANY USE OR REPRODUCTION, IN ANY FORM, WITHOUT PRIOR WRITTEN PERMISSION OF PROJECTS UNLIMITED, INC. IS PROHIBITED.  
© 2005, Projects Unlimited Inc.

SPECIFICATIONS

PARAMETERS	VALUES	UNITS
DIRECTIVITY	OMNI	-
SENSITIVITY	-44±3	dB
STANDARD OPERATING VOLTAGE	2	Vdc
MAX OPERATING VOLTAGE	10	Vdc
CURRENT CONSUMPTION (MAX)	0.5	mA
IMPEDANCE	2.2	kOhm
SIGNAL TO NOISE RATIO (MIN.)	60	dB
TERMINAL	PIN	-
INTERNAL CAPACITOR	N/A	pF

REVISIONS			
LTR	DESCRIPTION	DATE	APPROVED
-	RELEASED FROM ENGINEERING	1/27/06	
A	ADDED TERMINAL POLARITY	2/2/07	D.F.

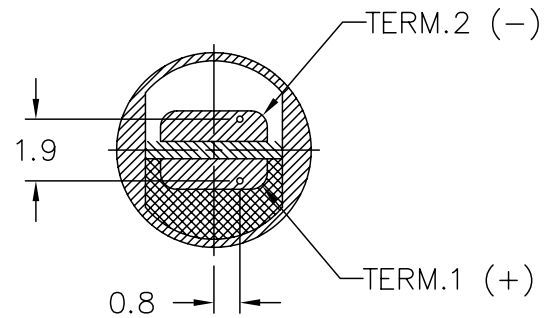
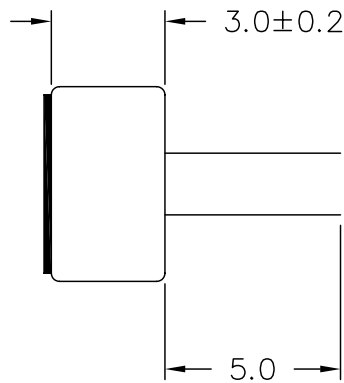
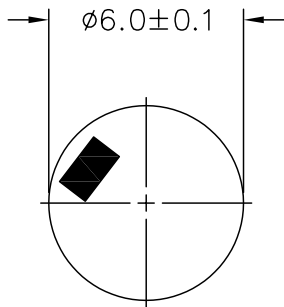

NOTES:

1. ALL DIMENSIONS ARE IN MILLIMETERS.
2. SPECIFICATION SUBJECT TO CHANGE OR WITHDRAWAL WITHOUT NOTICE.
3. THIS PART IS RoHS 2002/95/EC COMPLIANT.

FILE NAME  
POM-3044P-R.DWG

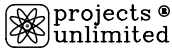
UNLESS OTHERWISE SPECIFIED: DIMENSIONS ARE IN MILLIMETERS, TOLERANCES ARE ±0.5 AND ANGLES ARE ±3°.		 <b>projects® unlimited</b> Dayton, Ohio									
<table border="1"> <thead> <tr> <th>APPROVALS</th> <th>DATE</th> </tr> </thead> <tbody> <tr> <td>DRAWN J.A.F.</td> <td>01/06</td> </tr> <tr> <td>CHECKED E.P.</td> <td>01/06</td> </tr> <tr> <td>APPROVED B.R.</td> <td>01/06</td> </tr> </tbody> </table>		APPROVALS	DATE	DRAWN J.A.F.	01/06	CHECKED E.P.	01/06	APPROVED B.R.	01/06	MICROPHONE	
APPROVALS	DATE										
DRAWN J.A.F.	01/06										
CHECKED E.P.	01/06										
APPROVED B.R.	01/06										
DO NOT SCALE DRAWING		SIZE A	DRAWING NO. POM-3044P-R								
		SCALE: N.T.S.	SHEET 1 OF 1								