

Customer Information Sheet

DRAWING No.: S1731-XXR SHEET 2 OF 2 IF IN DOUBT - ASK (C) NOT TO SCALE THIRD ANGLE PROJECTION ALL DIMENSIONS IN mm

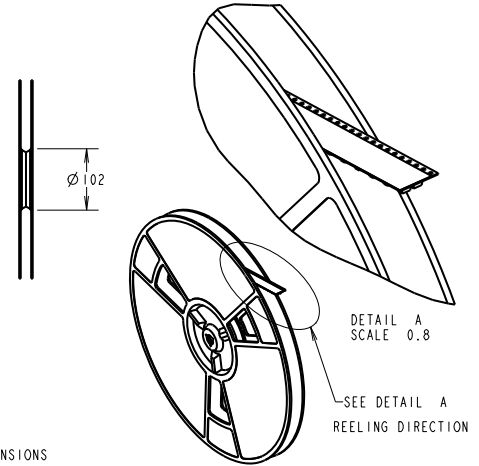
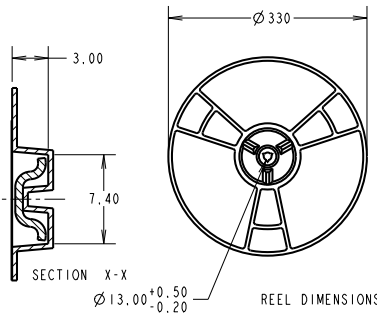
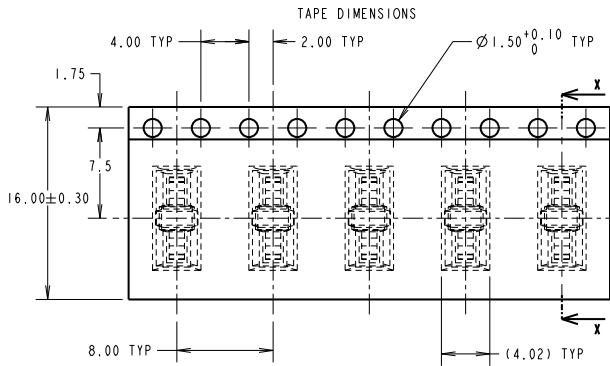

- NOTES:
 1. QUANTITY PER REEL = 2,500.
 2. THIS PRODUCT IS TAPED AND REELED IN ACCORDANCE WITH EIA-481 (ELECTRONIC INDUSTRIES ASSOCIATION).

RECOMMENDED PAD LAYOUT

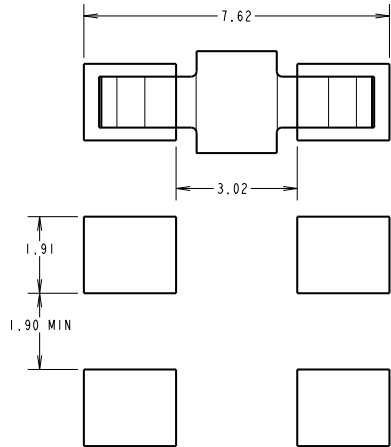

SINGLE COMPONENT DIMENSIONS

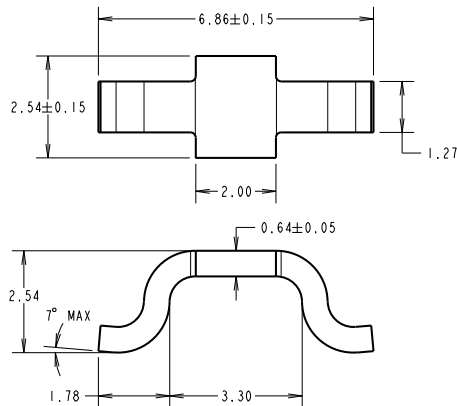

COMPONENT SPECIFICATION:
 MATERIAL = CW004A ETP COPPER
 FINISH:
 06 = 3µ 90/10 TIN/LEAD
 46 = 3µ 100X TIN OVER NICKEL
 CURRENT RATING = 10A (30°C TEMP RISE)

SW	4	30.09.10	10955
NAME ISS.	DATE	C/NOTE	
APPROVED: S. MCCULLAGH			
CHECKED: M. G. PLESTED			
DRAWN: M. G. PLESTED			
CUSTOMER REF.:			
ASSEMBLY DRG:			

HARWIN			THIS DRAWING AND ANY INFORMATION OR DESCRIPTIVE MATTER SET OUT HEREON ARE CONFIDENTIAL AND COPYRIGHT PROPERTY OF THE HARWIN GROUP AND MUST NOT BE DISCLOSED, LOANED, COPIED OR USED FOR MANUFACTURING, TENDERING OR FOR ANY OTHER PURPOSE WITHOUT THEIR WRITTEN PERMISSION.	TOLERANCES X. : ±1mm X.X : ±0.25mm X.XX : ±0.10mm X.XXX : ±0.01mm ANGLES : ±5° UNLESS STATED	MATERIAL: SEE ABOVE	TITLE: POWER SMT JUMPER LINK (TAPE AND REELED)	DRAWING NUMBER: S1731-XXR	SHT 2 OF 2
HARWIN USA TEL: 603 893 5376 FAX: 603 893 5396 mis@harwin.com	HARWIN Europe (UK) TEL: 023 9231 4545 FAX: 023 9231 4590 mis@harwin.co.uk	HARWIN Asia TEL: +65 6 779 4909 FAX: +65 6 779 3868 mis@harwin.com.sg						