

THIS DOCUMENT IS THE PROPERTY OF  
KEYSTONE ELECTRONICS CORP. AND  
SHALL NOT BE REPRODUCED, DISTRIBUTED  
OR USED AS A BASIS FOR MANUFACTURE  
WITHOUT PRIOR WRITTEN PERMISSION  
FROM KEYSTONE ELECTRONICS CORP.

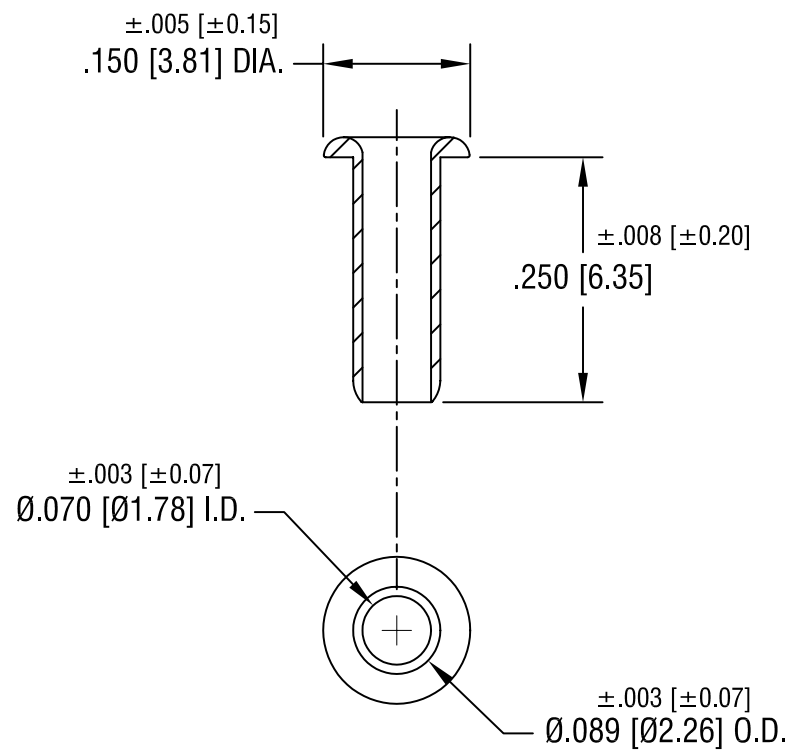

NOTE:

- 1. FINISH: TIN PLATE.  
.0001-.0003 TIN OVER  
.0001-.0002 COPPER

<b>KEYSTONE ELECTRONICS CORP.</b>			
ASTORIA, N.Y. 11105-2017			
PART NAME			
WIDE ROLL EYELET			
MATERIAL			
.009 [0.22] TH'K BRASS			
FINISH		DRN BY	DATE
AS NOTED		BOONE	3.11.03
		APP'D	SCALE
			5X
TOLERANCES	INCH	[MM]	CODE
DECIMAL	$\pm .005$	[ $\pm 0.15$ ]	C/M
ANGULAR	$\pm 1^\circ$		
UNLESS OTHERWISE SPECIFIED			DWG NO.
			<b>38</b>

DATE	DESCRIPTION	REV.