

DRAWING No.: P20-0545R

IF IN DOUBT - ASK

©

NOT TO SCALE

THIRD ANGLE PROJECTION

ALL DIMENSIONS IN mm

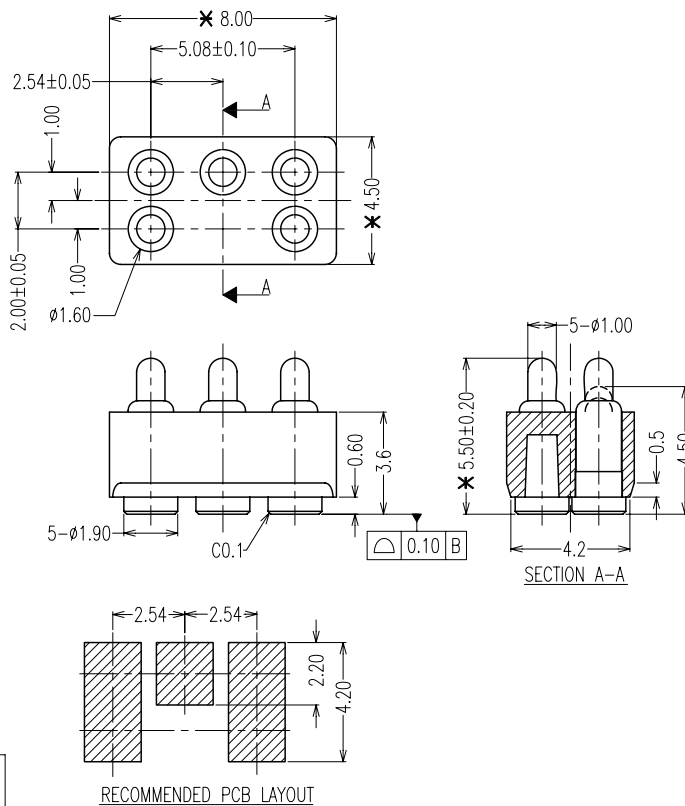

SPECIFICATIONS:

MATERIAL:-

HOUSING: BLACK PA9T (UL94V-0)

PLUNGER & BARREL: BRASS

SPRING: SUS 304

FINISH:-

CONTACT SURFACE: GOLD OVER NICKEL UNDERPLATE

ELECTRICAL:-

CURRENT RATING: 1 AMP

WORKING VOLTAGE: DC 12 V

CONTACT RESISTANCE: 50 mΩ MAX AT WORKING HT

MECHANICAL:-

DURABILITY: 10 000 CYCLES MIN.

UNLOADED HT: 5.5mm

WORKING HT: 4.5mm

SPRING FORCE: 80g ±20% AT WORKING HT

NOTES: ALL DIMENSIONS AND NOTES MARKED ✕ ARE CRITICAL AND MUST BE CHECKED IN ACCORDANCE WITH QUALITY DOC. Q1-02A

Allan	2	28.02.08	A113
Allan	1	01.08.06	-
NAME	ISS.	DATE	C/NOTE
APPROVED: <i>Ben</i>			
CHECKED:			
DRAWN: Allan			
CUSTOMER REF.:			
ASSEMBLY DRG:			

TOLERANCE:

DIMENSIONS	ANGLES
X. = ±0.25mm	±2.0°
X.X = ±0.15mm	±1.0°
X.XX = ±0.10mm	±0.5°

HARWIN

HARWIN USA
TEL: 603 893 5376
FAX: 603 893 5396
mis@harwin.com

HARWIN Europe (UK)
TEL: 023 9231 4545
FAX: 023 9231 4590
mis@harwin.co.uk

HARWIN Asia
TEL: +65 6 779 4909
FAX: +65 6 779 3868
mis@harwin.com.sg

THIS DRAWING AND ANY INFORMATION OR DESCRIPTIVE MATTER SET OUT HEREON ARE CONFIDENTIAL AND COPYRIGHT PROPERTY OF THE HARWIN GROUP AND MUST NOT BE DISCLOSED, LOANED, COPIED OR USED FOR MANUFACTURING, TENDERING OR FOR ANY OTHER PURPOSE WITHOUT THEIR WRITTEN PERMISSION.

TOLERANCES
X = ±1mm
X.X = ±0.25mm
X.XX = ±0.10mm
X.XXX = ±0.01mm
ANGLES = ±5°
UNLESS STATED

MATERIAL: SEE NOTES
FINISH: SEE NOTES
S/AREA: mm²

TITLE: PITCH 2.5X2mm HEIGHT 5.5mm
5-POS POGO PIN CONNECTOR

DRAWING NUMBER:
P20-0545R

SHT
1
OF
1