

- NOTES:
1. PART TO BE STRESS RELIEVED.
 2. 0.3 CHAMFER FOR LEAD-IN ON THREAD.
REMOVE ALL BURRS.
 3. THREAD TO BE MANUFACTURED IN ACCORDANCE WITH BS3643 PT.2 1981.

7	12.994	2723
6	2.5.91	1825
5	11.4.87	1081
4	24.3.86	955
3	8.2.86	932
2	30.1.84	777
1	21.7.81	1
ISS.	DATE	C/N
DRAWN: I.SANDY		
CHECKED: <i>[Signature]</i>		
APPD.: <i>[Signature]</i>		
CUSTOMER REF.		
ASSEMBLY DRG:		



HARWIN PLC UK TEL: (0705) 370451 FAX: (0705) 324010	HARWIN INC U.S.A. TEL: (812) 285-0055 FAX: (812) 285-0056	HARWIN PTE SINGAPORE TEL: 7794909 FAX: 7793868
--	--	---

TOLERANCES	
X.	±1mm
X.X	±0.25mm
X.XX	±0.10mm
X.XXX	±0.01mm
ANGLES	±1°
IF IN DOUBT - ASK	

MATERIAL: BRASS CZ121 TO BS2874 (BRM1198)	FINISH: NICKEL F0203
S/AREA: 260.0 mm ²	

TITLE: M3 CAPTIVE SPACER	DRAWING NUMBER: R4351-02	SHT. 1 OF 1
-----------------------------	------------------------------------	----------------------

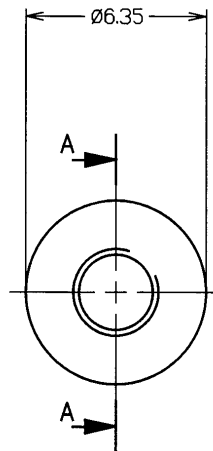
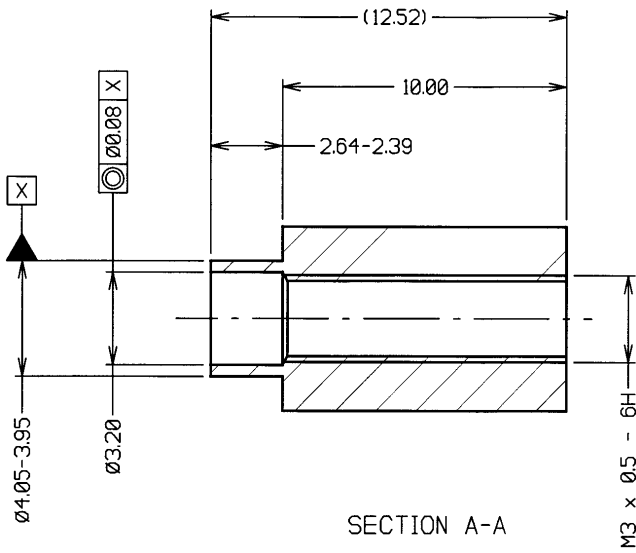

SECTION A-A

NOTES:

1. TO BE ANNEALED AT 400°C FOR A PERIOD OF 2 HOURS AND ALLOWED TO COOL NATURALLY INSIDE SWITCHED 'OFF' OVEN.
2. 0.25mm CHAMFERS FOR LEAD-IN ON THREAD.
3. REMOVE ALL BURRS.
4. THREAD TO BE MANUFACTURED ACCORDING TO BS3643 PT.2 1981.

5	23.10.96	3566
4	03.05.91	1825
3	22.12.87	1210
2	30.01.84	777
1	21.07.81	----
ISS.	DATE	C/N
APPROVED: <i>[Signature]</i>		
CHECKED: <i>[Signature]</i>		
DRAWN: A. LIOTTA		
CUSTOMER REF.		
ASSEMBLY DRG:		

HARWIN

HARWIN INC U.S.A. TEL: (812) 285 0055 FAX: (812) 285 0056	HARWIN PLC U.K. TEL: 01705 370451 FAX: 01705 324010	HARWIN PTE SINGAPORE TEL: 65 7794909 FAX: 65 7793868	HARWIN CONNECTORS KOREA TEL: 822 521 0747 FAX: 822 521 0749
---	---	--	---

TOLERANCES
 X. - ±1mm
 X.X - ±0.25mm
 X.XX - ±0.10mm
 X.XXX - ±0.01mm
 ANGLES - ±1°
 UNLESS STATED

MATERIAL:
BRASS CZ121 TO BS2874

FINISH: F0203 (NICKEL)

S/AREA: 442.9 mm²

TITLE:
CAPTIVE SPACER (M3)

DRAWING NUMBER:
R4352-02

SHT
1 OF 1

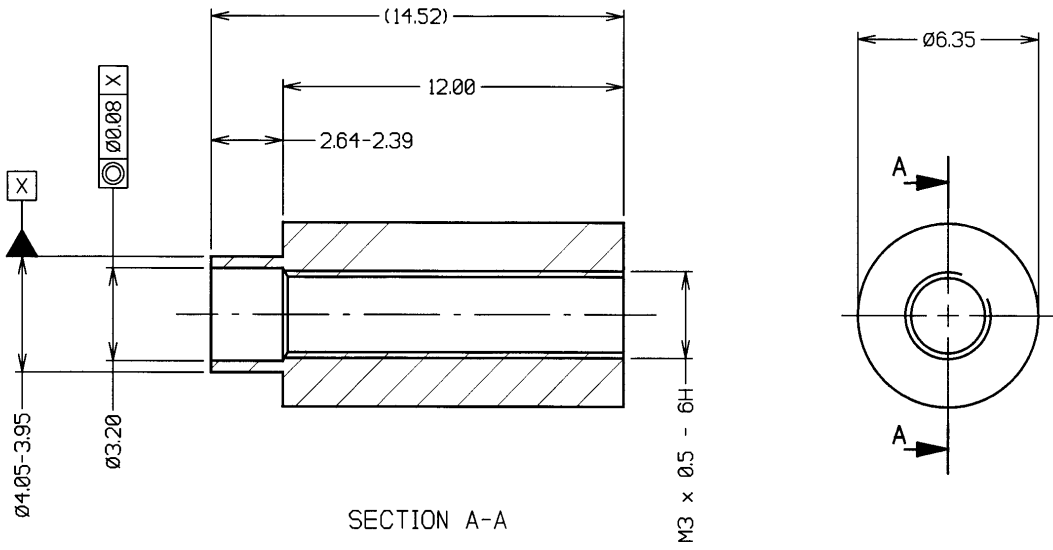

- NOTES:
1. TO BE ANNEALED AT 400°C FOR A PERIOD OF 2 HOURS AND ALLOWED TO COOL NATURALLY INSIDE SWITCHED 'OFF' OVEN.
 2. 0.25mm CHAMFERS FOR LEAD-IN ON THREAD.
 3. REMOVE ALL BURRS.
 4. THREAD TO BE MANUFACTURED ACCORDING TO BS3643 PT.2 1981.

7	23.10.96	3566
6	03.05.91	1825
5	11.04.87	1081
4	24.03.86	955
3	08.02.86	932
2	30.01.84	777
1	21.07.81	----
ISS.	DATE	C/N
APPROVED: <i>[Signature]</i>		
CHECKED: <i>[Signature]</i>		
DRAWN: A. LIOTTA		
CUSTOMER REF.		
ASSEMBLY DRG:		



HARWIN INC U.S.A. TEL: (812) 285 0055 FAX: (812) 285 0056	HARWIN PLC U.K. TEL: 01705 370451 FAX: 01705 324010	HARWIN PTE SINGAPORE TEL: 65 7794909 FAX: 65 7793868	HARWIN CONNECTORS KOREA TEL: 822 521 0747 FAX: 822 521 0749
---	---	--	---

TOLERANCES
 X - ±1mm
 X.X - ±0.25mm
 X.XX - ±0.10mm
 X.XXX - ±0.01mm
 ANGLES - ±1°
 UNLESS STATED

MATERIAL:
BRASS CZ121 TO BS2874

FINISH: F0203 (NICKEL)

S/AREA: 507.5 mm²

TITLE: CAPTIVE SPACER (M3)

DRAWING NUMBER: R4353-02

SHT
1 OF 1

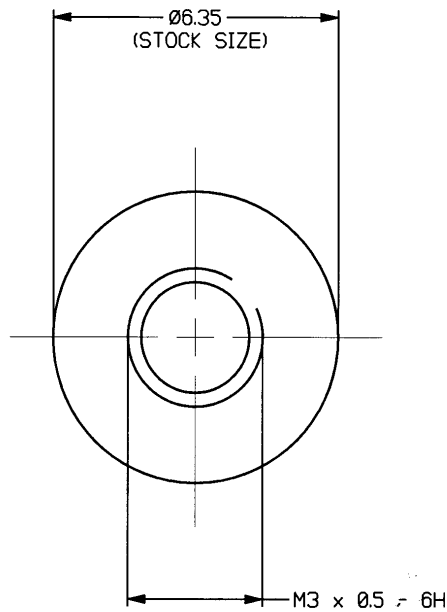
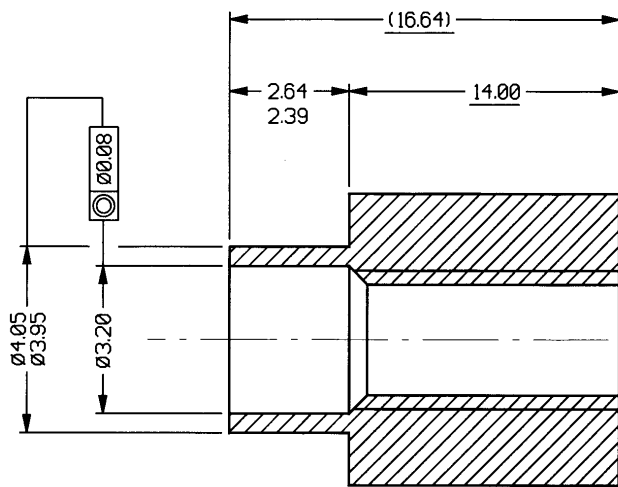

- NOTES:
1. PART TO BE STRESS RELIEVED.
 2. 0.3 CHAMFER FOR LEAD-IN ON THREAD. REMOVE ALL BURRS.
 3. THREAD TO BE MANUFACTURED IN ACCORDANCE WITH BS3643 PT.2 1981.

1	20.9.94	
ISS.	DATE	C/N
DRAWN: I.SANDY		
CHECKED: <i>[Signature]</i>		
APPD: <i>[Signature]</i>		
CUSTOMER REF.		
ASSEMBLY DRG:		

HARWIN

HARWIN PLC U.K. TEL: (0705) 370451 FAX: (0705) 324010	HARWIN INC U.S.A. TEL: (812) 285-0055 FAX: (812) 285-0056	HARWIN PTE SINGAPORE TEL: 7794909 FAX: 7793868
--	--	---

TOLERANCES
X. ±1mm
X.X ±0.25mm
X.XX ±0.10mm
X.XXX ±0.01mm
ANGLES ±1°
IF IN DOUBT - ASK

MATERIAL: BRASS CZ121 TO BS2874 (BRM1198)
FINISH: NICKEL F0203
S/AREA: 260.0 mm ²

TITLE: M3 CAPTIVE SPACER	DRAWING NUMBER: R4354-02	SHT. 1 OF 1
-----------------------------	------------------------------------	----------------