

Customer Information Sheet

DRAWING No.: R60-300XX02

SHEET 2 OF 2

IF IN DOUBT - ASK

©

NOT TO SCALE

THIRD ANGLE PROJECTION

ALL DIMENSIONS IN mm

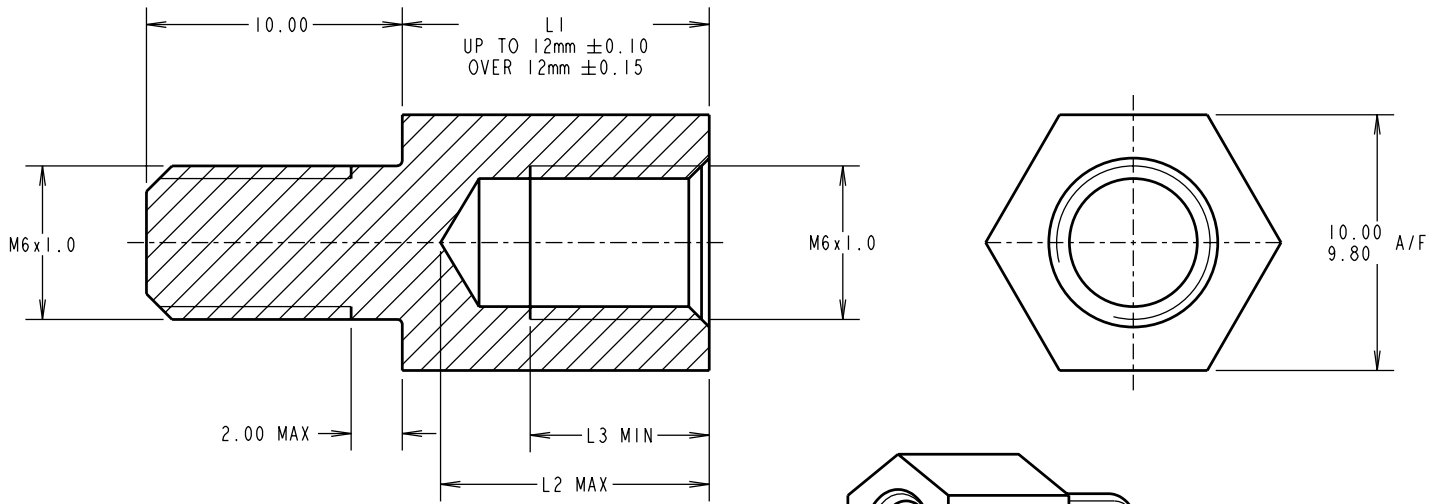

PART No.	L1	L2	L3
R60-3001002	10.00	9.0	5.00
R60-3001102	11.00	10.0	6.00
R60-3001202	12.00	11.0	7.00
R60-3001302	13.00	12.0	8.50
R60-3001402	14.00	13.0	9.50
R60-3001502	15.00	14.0	10.50
R60-3001602	16.00	15.0	11.50

PART No.	L1	L2	L3
R60-3001802	18.00	16.5	11.50
R60-3002002	20.00	16.5	11.50
R60-3002502	25.00	16.5	11.50
R60-3003002	30.00	16.5	11.50
R60-3003502	35.00	16.5	11.50
R60-3004002	40.00	16.5	11.50
R60-3005002	50.00	16.5	11.50

ORDER CODE:
R60-300XX02
LENGTH L1 IN mm _____

SF	5	10.10.08	10174
NAME	ISS.	DATE	C/NOTE
APPROVED: SF			
CHECKED: MGP			
DRAWN: A. LIOTTA			
CUSTOMER REF.:			
ASSEMBLY DRG:			

HARWIN

HARWIN USA
TEL: 603 893 5376
FAX: 603 893 5396
mis@harwin.com

HARWIN Europe (UK)
TEL: 023 9231 4545
FAX: 023 9231 4590
mis@harwin.co.uk

HARWIN Asia
TEL: +65 6 779 4909
FAX: +65 6 779 3868
mis@harwin.com.sg

THIS DRAWING AND ANY INFORMATION OR DESCRIPTIVE MATTER SET OUT HEREON ARE CONFIDENTIAL AND COPYRIGHT PROPERTY OF THE HARWIN GROUP AND MUST NOT BE DISCLOSED, LOANED, COPIED OR USED FOR MANUFACTURING, TENDERING OR FOR ANY OTHER PURPOSE WITHOUT THEIR WRITTEN PERMISSION.

TOLERANCES
X. = ±1mm
X.X = ±0.25mm
X.XX = ±0.10mm
X.XXX = ±0.01mm
ANGLES = ±5°
UNLESS STATED

MATERIAL:
BRASS CW614N M TO BS EN 12164 (CuZn39Pb3)
FINISH: NICKEL
S/AREA: mm²

TITLE:
M6 HEXAGONAL MALE/FEMALE SPACER
DRAWING NUMBER:
R60-300XX02

SHT
2 OF 2