

Customer Information Sheet

DRAWING No.: K3601-91

SHEET 2 OF 2

IF IN DOUBT - ASK

©

NOT TO SCALE

THIRD ANGLE PROJECTION

ALL DIMENSIONS IN mm

SEE COMPONENT SPECIFICATION C034XX FOR ASSEMBLY INSTRUCTIONS AND TECHNICAL DATA

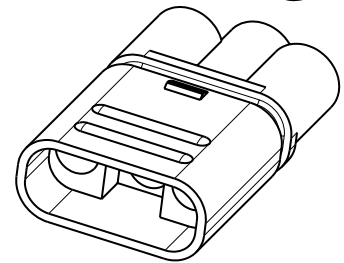
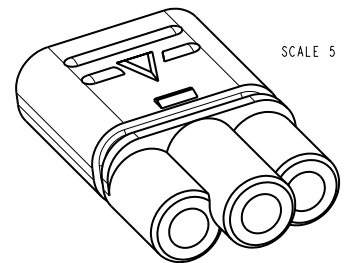
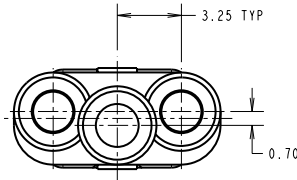
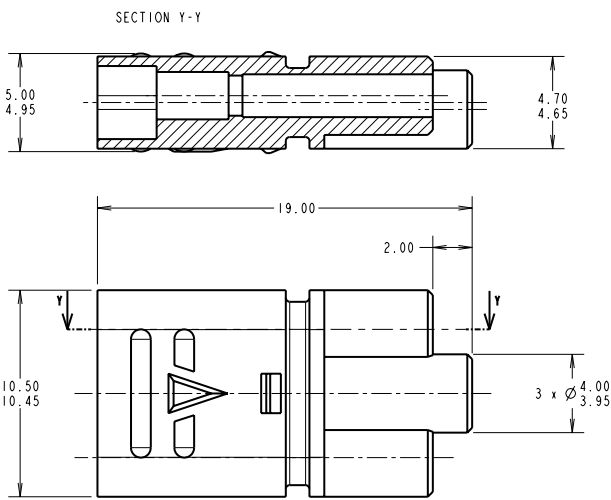

ORDER CODE:
K3601-91
COLOUR:
91 - GREY

SPECIFICATIONS:

- ELECTRICAL:**
 CURRENT RATING @ 25°C = 10A MAX
 CURRENT RATING @ 85°C = 7.5A MAX
 WORKING VOLTAGE = 250V AC/DC
 VOLTAGE PROOF = 750V AC/DC
 CONTACT RESISTANCE (INITIAL) = 10mΩ MAX
 CONTACT RESISTANCE (AFTER CONDITIONING) = 15mΩ MAX
 INSULATION RESISTANCE (INITIAL) = 1,000MΩ @ 500V DC FOR 1 MINUTE
 INSULATION RESISTANCE (AFTER CONDITIONING) = 100MΩ @ 500V DC FOR 1 MINUTE
- MECHANICAL:**
 DURABILITY = 100 OPERATIONS
 RETENTION FORCE OF CONTACT IN MOULDING (INITIAL) = 20N MIN
 INSERTION FORCE OF CONNECTOR ASSEMBLY = 40N MAX
 WITHDRAWAL FORCE OF CONNECTOR ASSEMBLY = 10N MIN
 CRIMP PULL-OFF FORCE (BS 5G 178) = 142N MIN
 PROTECTION RATING (BS EN 60529) = IP55 (SEE NOTE 5)
 IP67 (WITH 'O' RING K3605-00)
- ENVIRONMENTAL:**
 TEMPERATURE RANGE = -40°C TO +105°C

NOTES:

- FOR COMPLETE SPECIFICATION, SEE COMPONENT SPECIFICATION C034XX (LATEST ISSUE). THE COMPONENT SPECIFICATION ALSO INCLUDES NOTES ON ASSEMBLY METHODS.
- THIS MOULDING CAN BE USED WITH 2-OFF SOLDER-BUCKET CONTACTS K3603-06, OR 2-OFF CRIMP CONTACTS K3607-06 (SEE INSTRUCTION SHEET IS-01). SPECIFICATIONS LISTED HERE APPLY FOR A COMPLETE ASSEMBLY OF MOULDINGS AND CONTACTS.
- ASSEMBLY TOOL ZK3610-00 CAN BE USED TO AID INSERTION AND EXTRACTION OF CONTACTS FROM MOULDING (SEE INSTRUCTION SHEET IS-22).
- THIS MOULDING MATES WITH 2-WAY PIN MOULDING K3600-91.
- THIS MOULDING MAY BE BACK-POTTED TO ACHIEVE A PROTECTION RATING OF IP55 (WHEN MATED). IF AN 'O' RING (PART No. K3605-00) IS FITTED, THE PROTECTION RATING IS IP67 (MATED AND BACK-POTTED).
- ALL TOLERANCES ARE ±0.05 UNLESS OTHERWISE STATED.

RA	2	15.06.09	10352
NAME	ISS.	DATE	C/NOTE
APPROVED: R. ADDE			
CHECKED: M. G. PLESTED			
DRAWN: W. J. BOURNE			
CUSTOMER REF.:			
ASSEMBLY DRG:			

HARWIN			THIS DRAWING AND ANY INFORMATION OR DESCRIPTIVE MATTER SET OUT HEREON ARE CONFIDENTIAL AND COPYRIGHT PROPERTY OF THE HARWIN GROUP AND MUST NOT BE DISCLOSED, LOANED, COPIED OR USED FOR MANUFACTURING, TENDERING OR FOR ANY OTHER PURPOSE WITHOUT THEIR WRITTEN PERMISSION.	TOLERANCES X.X = ±1mm X.XX = ±0.2mm X.XXX = ±0.01mm ANGLES = ±5° UNLESS STATED	MATERIAL: 30% GLASS-FILLED POLYESTER UL94V-0, GREY	TITLE: POWER CONNECTOR 2-WAY SOCKET MOULDING
HARWIN USA TEL: 603 893 5376 FAX: 603 893 5396 mis@harwin.com	HARWIN Europe (UK) TEL: 023 9231 4545 FAX: 023 9231 4590 mis@harwin.co.uk	HARWIN Asia TEL: +65 6 779 4909 FAX: +65 6 779 3868 mis@harwin.com.sg				