

12BH611 (Shown)

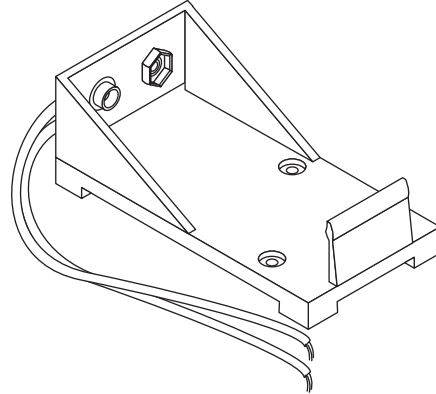

12BH610 (Shown)

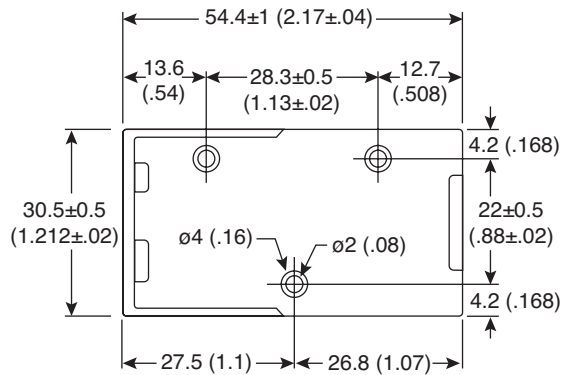

Bottom View

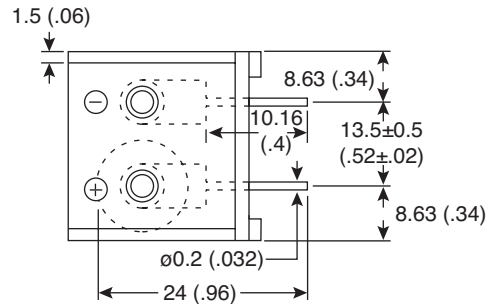

DIMENSIONS: mm (In.)

SPECIFICATIONS	
12BH610:	6" Leads
12BH611:	PC Leads, ø.032
Body Material:	ABS
Contacts:	Nickel Plated Steel Spring
Terminals:	Nickel Plated Brass, Snap Fastener Male/Female Terminals
Color:	Black
Temperature Range:	-40°C ~ +85°C
Temperature Rating:	80°C
Weight:	7.5 grams
UL Flammability Rating:	none

Available from Mouser Electronics
 1-800-346-6873
 www.mouser.com

EPD-200183