

Ø.125 [Ø3.18] (2) PLS  
DIA. MTG HOLE

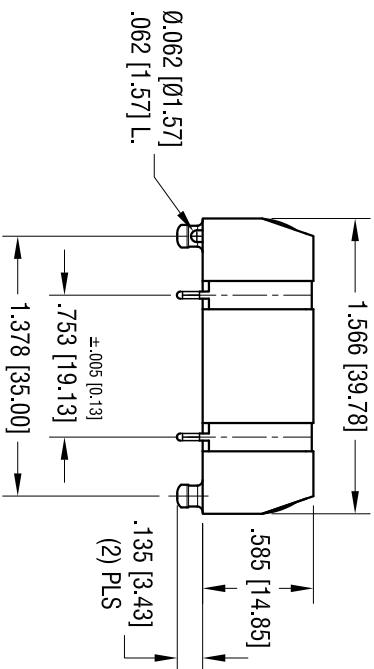

- NOTE:
1. BASE: MATL: HEAT RESISTANCE NYLON STANVYL 46 OR EQUIVALENT
  2. CONTACT: MATL: .012 [0.30]THK PHOSPHOR BRONZE FINISH: TIN NICKEL PLATE

DATE	DESCRIPTION	REV.
8.24.10	CHANGE AS PER ECN 10-062	A
10.04.10	CHANGE PER ECN 10-069	B
10.26.10	CHANGE PER ECN 10-075	C
4.08.11	CHANGE PER ECN 11-046	D

THIS DOCUMENT IS THE PROPERTY OF KEYSTONE ELECTRONICS CORP. AND SHALL NOT BE REPRODUCED, DISTRIBUTED OR COPIED IN ANY MANNER WITHOUT WRITTEN PERMISSION FROM KEYSTONE ELECTRONICS CORP.

<b>KEYSTONE ELECTRONICS CORP.</b>			
www.keystec.com • ASTORIA, N.Y. 11105-2017 • Tel (718) 956-8900			
PART NAME DUAL THIN BATTERY HOLDER, 18650			
MATERIAL AS NOTED			
FINISH AS NOTED		DRN BY NT	DATE 8.19.10
TOLERANCES DECIMAL ± .010 [± 0.25 ] ANGULAR ± 1°		CODE C	DWG NO. 1049
		APPD	SCALE 1.25X