

Cooling Products

Sizing an Air Conditioner

Sizing an Air Conditioner

The proper selection of an air conditioner is determined by the following steps:

- Step 1) Internal heat load quoted as Watts that must be dissipated.
- Step 2) The exposed surface area of the enclosure.
- Step 3) Temperature differential required between maximum inside temperature and maximum outside ambient.
- Step 4) Final calculation of the above.

Step One

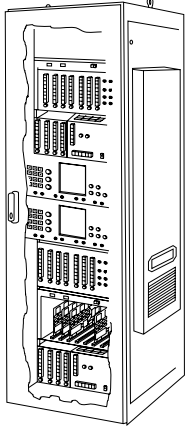

1 Watt = 3.413 BTU/H

Determine the internal heat load (in Watts) that must be dissipated.

Step Two

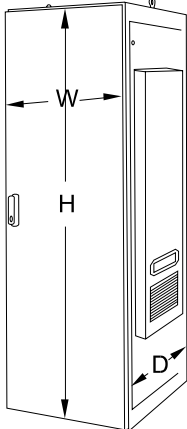

1 m² = 10.76 ft²

Calculate the exposed surface area of the enclosure:

$$\frac{2(h" \times w") + 2(h" \times d") + (w" \times d")}{144} = \text{Area (ft}^2\text{)}$$

(Example for freestanding enclosure)

Step Three

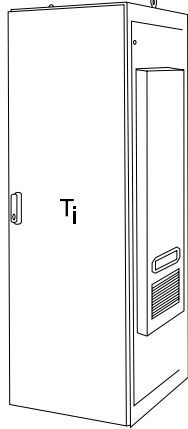

1°C or 1°KΔT=1.8°FΔT

Determine the temperature differential by subtracting the maximum allowable temperature inside the enclosure (T_i) from the maximum ambient temperature outside the enclosure (T_o).

T_o-T_i = DT

Step Four

(Watts x 3.413) + [1.25 x Area ft² X DT (°F)] = BTU/H

Capacity Required
BTU/H. Capacity Rating.

The DTS/DTT offering is available in the most popular selection of cooling capacities, sizes, voltages and mounting configurations. Available capacities range from 1,200 to 16,000 BTU/H in both side mounting and top mounting models. All models use powerful radial fans for maximum air circulation inside the enclosure in ambient temperatures of 125°F (+52°C). Models from 2,000 BTU/H capacity are equipped with thermal expansion valves for optimal use of the evaporator heat exchange surface under all operating conditions. For additional protection of the compressor motor, these valves are supplied as standard with Maximum Operating Pressure control devices (MOP). For energy conservation, the use of hot gas bypass valves is limited to the unloaded starting and control of large compressors from 8,000 BTU/H upwards. All air conditioners were developed, designed and subject to final inspections in accordance with international standards.

Cooling Products

General Specifications for All Air Conditioners

Construction:	Outer shell of sheet steel.
Closed Loop Cooling:	Ambient outside air is never mixed with clean dry enclosure air.
Operating Temperature:	Minimum +46 F (+8 C) Maximum +125 F (52 C). Optional low ambient kit is available
Gasketing:	Is provided and/or installed on all units to maintain NEMA ratings specified.
Templates:	Provided on all units for easy layout of cutouts and mounting.
Power:	Available in 115 V 60 Hz, 110 V 50 Hz and 230 V, 460 50/60Hz 3 phase.
Filter:	Removable filter mat made from synthetic fibers are reusable and can be rinsed clean.
Refrigerants:	All models use environmentally friendly R134a.
Fans:	All blower motors are thermal protected and sealed with permanent lubricants.
Condensate Disposal:	Built in condensate evaporators are standard on most models. All units feature a condensate drain fitting complete with hose attachment.
Insulation:	Cold components, lines and evaporator compartment insulated for maximum efficiency and protection against condensation.
Quality Assurance:	Prior to charging, the refrigeration system is hermetically sealed with all joints brazed under protection gas atmosphere to exclude any internal scale. After a thorough leak test every unit undergoes safety and function checks, then is serialized and packed into sturdy boxes prior to shipment.
Installation Manuals:	Included with all models are detail drawings, mounting, schematic and wiring diagrams, a trouble shooting checklist and warranty information.

Product Summary

Side Mount Air Conditioners

Part No.	NEMA Protection	Rating BTU/H	Rated Voltage	Hz	Height	Width	Depth
DTS1200A115LG	12	1,200	115	60	13.00	14.76	7.48
DTS1200A230LG	12	1,200	230	50/60	13.00	14.76	7.48
DTS2000A115LG	12	2,000	115	60	17.52	12.40	10.04
DTS2000A230LG	12	2,000	230	50/60	17.52	12.40	10.04
DTS3081A115N4SS	4X	2,500	115	60	20.15	10.05	10.77
DTS3081A230N4SS	4X	2,500	115	60	20.15	10.05	10.77
DTS3041A115LG	12	2,500	115	60	20.15	10.05	10.77
DTS3041A230LG	12	2,500	230	50/60	20.15	10.05	10.77
DTS3500A115LG	12	3,500	115	60	36.00	15.35	7.87
DTS3500A230LG	12	3,500	230	50/60	36.00	15.35	7.87
DTS3141A115LG	12	4,000	115	60	29.46	15.55	9.38
DTS3161A115N3LG	3R/4	4,000	115	60	29.46	15.55	9.32
DTS3141A230LG	12	4,000	230	50/60	29.46	15.55	9.38
DTS3181A115N4SS	4X	4,000	115	60	29.46	15.55	9.32
DTS3161A230N3LG	3R/4	4,000	230	50/60	29.46	15.55	9.32
DTS3181A230N4SS	4X	4,000	230	50/60	29.46	15.55	9.32
DTS3241A115LG	12	7,500	115	60	47.61	15.55	10.65
DTS3261A115N3LG	3R/4	7,500	115	60	47.61	15.55	10.51
DTS3281A115N4SS	4X	7,500	115	60	47.61	15.55	10.51
DTS3241A230LG	12	7,500	230	50/60	47.61	15.55	10.65
DTS3261A230N3LG	3R/4	7,500	230	50/60	47.61	15.55	10.51
DTS3281A230N4SS	4X	7,500	230	50/60	47.61	15.55	10.51
DTS8000A115LG	12	8,000	115	60	53.15	15.63	10.63
DTS8000A230LG	12	8,000	230	50/60	53.15	15.63	10.63
DTS12000A115LG	12	12,000	115	60	53.15	15.63	10.63
DTS12000A230LG	12	12,000	230	50/60	53.15	15.63	10.63
DTS9841A460LG	12	16,000	460	60	60.98	19.09	14.17

A115 units can be operated 50 Hz at 110 V

Top Mount Air Conditioners

Part No.	NEMA Protection	Rating BTU/H	Rated Voltage	Hz	Height	Width	Depth
DTT4500A115LG	12	4,500	115	60	15.94	23.62	15.35
DTT4500A230LG	12	4,500	230	50/60	15.94	23.62	15.35

A115 units can be operated 50 Hz at 110 V and A460 units can be operated at 50Hz at 380V.

Technical references and DXF downloads available at www.hamfmfg.com

All dimensions in inches unless specified otherwise

Quality Enclosures. Service Excellence.

Side Mounting DTS Series

1200 BTU/H



Description

- Designed for side mounting where hot spot cooling or low capacity cooling is required.
- Compact design uses minimal surface area.
- Closed loop cooling ensures air is recirculated without ever mixing with contaminated ambient air.

Standards

- Maintains NEMA 12 rating
- IP 54
- UR, cUR and CE

Features

- R134a refrigerant.
- Thermostat control.
- Continuous air circulation from high capacity fans.

- EMI/RFI suppression meets CE.
- Line cord with plug (115 V).
- Washable filter mat protected within an easily removable grill.
- Gasket, mounting kit and template for enclosure cutout and drilling are included.
- Condensate drain hose and clamp provided.
- Exterior case easily removable for field service.
- Q Mount allows unit to hang in place for easy installation.

Accessories

- Gaskets...see page 400
- Replacement filters...see page 400
- Replacement grill...see page 400



Climate Control

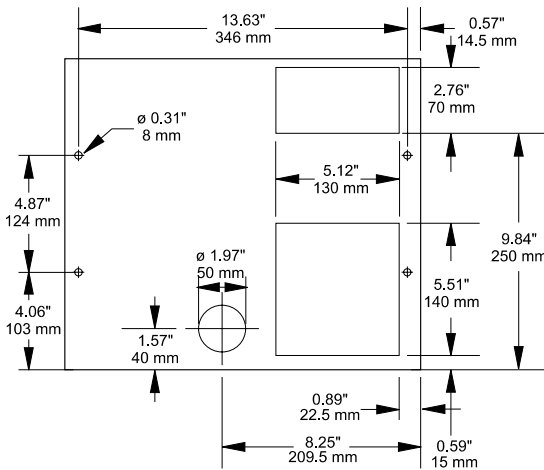

Drilling Template

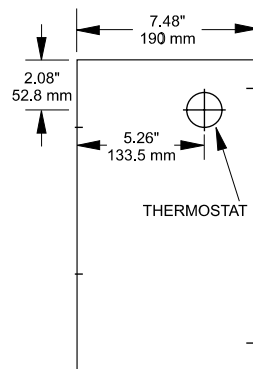

Right Side View

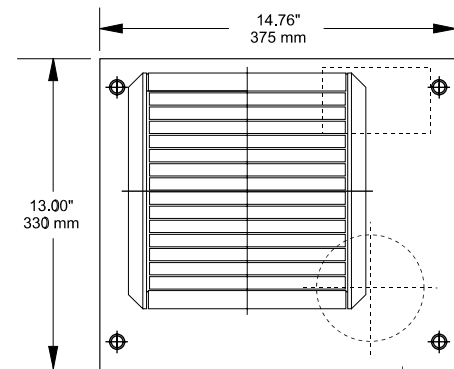

Front View

Part Number	Ship Wt. lbs
DTS1200A115LG	42
DTS1200A230LG	42

Technical Data

Electrical Data	DTS1200A115LG	DTS1200A230LG
Rated Voltage	115 V 60 Hz 110 V 50 Hz	230 V 50/60 Hz
Range of Operation	103-127 V	207-253 V
Power Consumption	200 W	200 W
Running Amps	2.2 A	1.3 A
Starting Current	15.7 A	9.5 A
Line Cord	With plug	Without plug

Refrigeration Data	
Rated Capacity	1,200 BTU/H (350 Watts)
Type of Refrigerant	R134a
Refrigerant Charge	280 g
Adjustable Thermostat	Factory setting +95°F (+35°C)
Max. Ambient Air Temp.	+125°F (+52°C)
Min. Ambient Air Temp.	+46°F (+8°C)
Air Capacity (unrestricted)	Internal Circulation 106 CFM External Circulation 230 CFM
Condensate Discharge	Direct via tube
Filter Mat	150 g/m ²
Db Noise Level	≤ 62 dB(A)
Unit Weight	40 lbs (18 kg)
Exterior Case	Galvanized sheet steel
Finish	RAL7035 light grey finish
NEMA Rating	Enclosures IP 54/NEMA 12

Technical references and DXF downloads available at www.hamfmfg.com

All dimensions in inches unless specified otherwise

Side Mounting DTS Series 2000 BTU/H



Description

- Compact design for side mounting on any enclosure surface where hot spot cooling or low capacity cooling is required.
- Closed loop cooling ensures clean enclosure air is recirculated without ever mixing with contaminated ambient air.

Standards

- Maintains enclosure's NEMA 12 rating
- IP 54
- UR, cUR and CE

Features

- R134a refrigerant.
- Thermostat control.
- Line cord with plug (115 V).
- Washable filter mat protected within an easily removable grill.

- Expansion valve permits increased efficiency through improved evaporator heat transfer and less frequent compressor operation.
- Built in condensate evaporator.
- Continuous air circulation from high capacity fans.
- EMI/RFI suppression meets CE.
- Gasket, mounting kit and template for cutout and drilling are included.
- Condensate drain hose and clamp.
- Exterior case easily removable for field service.
- Q Mount allows unit to hang in place for easy installation.

Accessories

- Gaskets...see page 400
- Replacement filters...see page 400
- Replacement grill...see page 400

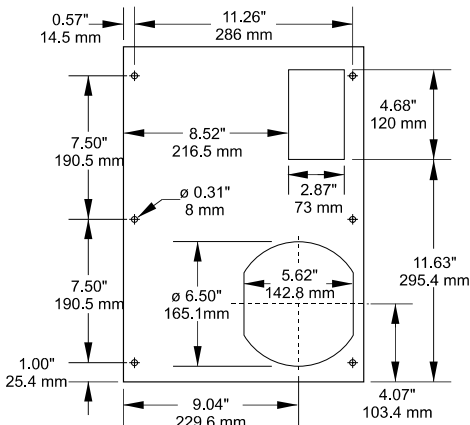

Drilling Template

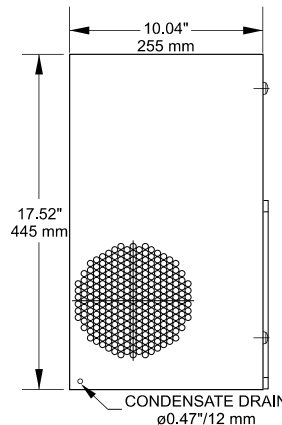

Left Side View

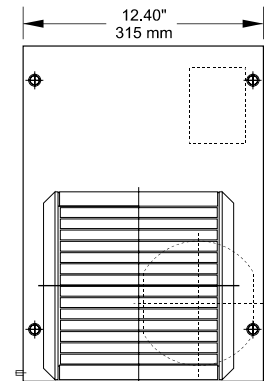

Front View

Climate Control

Part Number	Ship Wt. lbs
DTS2000A115LG	54
DTS2000A230LG	54

Technical Data

Electrical Data	DTS2000A115LG	DTS2000A230LG
Rated Voltage	115 V 60 Hz	230 V 50/60 Hz
	110 V 50 Hz	
Range of Operation	103-127 V	207-253 V
Power Consumption	270 W	230 W
Running Amps	2.9 A	1.3 A
Starting Current	13.8 A	7.4 A
Line Cord	With plug	Without plug

Refrigeration Data	
Rated Capacity	2,000 BTU/H (580 Watts)
Type of Refrigerant	R134a
Refrigerant Charge	300 g
Adjustable Thermostat	Factory setting +95°F (+35°C)
Max. Ambient Air Temp.	+125°F (+52°C)
Min. Ambient Air Temp.	+46°F (+8°C)
Air Capacity (unrestricted)	Internal Circulation 230 CFM External Circulation 230 CFM
Condensate Discharge	Condensate evaporator
Filter Mat	150 g/m ²
Db Noise Level	≤ 62 dB(A)
Unit Weight	51 lbs (23 kg)
Exterior Case	Galvanized sheet steel
Finish	RAL7035 light grey finish
NEMA Rating	Enclosures IP 54/NEMA 12

Side Mounting DTS Series

2500 BTU/H



Description

- Compact design for side mounting on any enclosure surface where hot spot or low capacity cooling is required.
- Closed loop cooling ensures clean enclosure air is recirculated without ever mixing with contaminated ambient air.

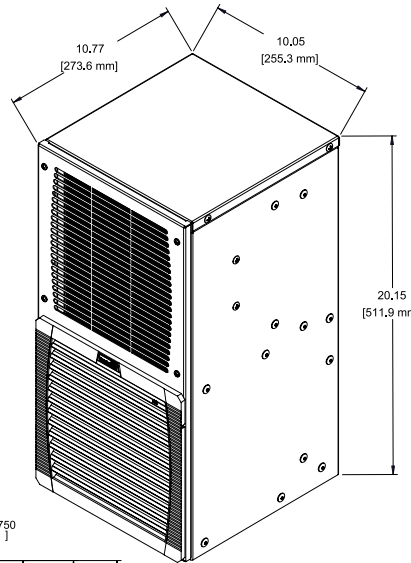

Standards

- Maintains enclosure's NEMA 12 rating
- IP 54
- UL, cUL and CE

Features

- R134a refrigerant.
- Thermostat control accessible from inside enclosure.
- Expansion valve increases efficiency with improved evaporator heat transfer and less frequent compressor operation.
- Direct condensate discharge via drain hose.
- Continuous air circulation from high capacity fans.
- EMI/RFI suppression meets CE.
- Self-diagnostics on startup.
- Fault indication via LED light.
- Door contact for power down when enclosure door is opened.
- Gasket, mounting kit and template for cutout and drilling are included.
- Condensate drain hose and clamp
- Easy install with "Click & Fit" system

Accessories

- Gaskets...see page 400
- Remote door switch...see page 400

Climate Control

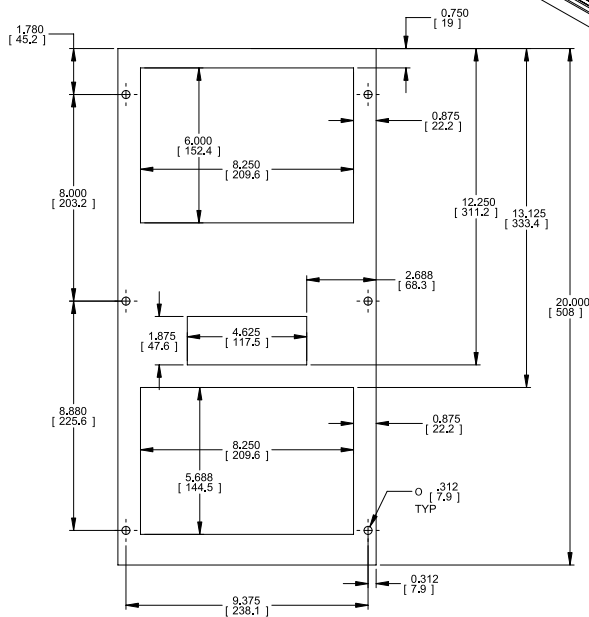

Technical Data

Electrical Data	DTS3041A115LG	DTS3041A230LG
Rated Voltage	115v 60 Hz	230v 50/60 Hz
	110v 50 Hz	
Range of Operation	103-127v	207-253v
Power Consumption	690 W	724 W
Running Amps	6.0 A	3.3 A
Starting Current	28 A	14.4 A
Line Cord	With Plug	With Plug

Part Number	Ship Wt. lbs
DTS3041A115LG	56
DTS3041A230LG	56

Refrigeration Data

Rated Capacity	2500 BTU/H (585 Watts)
Type of Refrigerant	R134a
Refrigerant Charge	400 g
Adjustable Set Points	Factory setting +95°F (+35°C)
Max. Ambient Air Temp.	+131°F (+55°C)
Min. Ambient Air Temp.	+59°F (+15°C)
Air Capacity (unrestricted)	Internal Circulation 191 CFM External Circulation 88 CFM
Condensate Discharge	Condensate Drain
Filter Mat	Filterless
Db Noise Level	≈ 64 dB(A)
Unit Weight	51 lbs (23 kg)
Exterior Case	Galvanized sheet steel
Finish	RAL7035 light grey finish
NEMA Rating	Enclosures IP 54/NEMA 12

Technical references and DXF downloads available at www.hamfmg.com

All dimensions in inches unless specified otherwise

Side Mounting DTS Series

3500 BTU/H



Description

- Compact design for side mounting on any enclosure surface where hot spot or low capacity cooling is required.
- Closed loop cooling ensures clean enclosure air is recirculated without ever mixing with contaminated ambient air.

Standards

- Maintains enclosure's NEMA 12 rating
- IP 54
- UR, cUR and CE

Features

- R134a refrigerant.
- Thermostat control.
- Expansion valve increases efficiency with improved evaporator heat transfer and less frequent compressor operation.
- Built in condensate evaporator.
- Continuous air circulation from high capacity fans.
- EMI/RFI suppression meets CE.
- Line cord with plug (115 V).
- Self-diagnostics on startup.
- Fault indication via LED light.
- Door contact for power down when enclosure door is opened.
- Washable filter mat protected within an easily removable grill.
- Gasket, mounting kit and template for cutout and drilling are included.
- Condensate drain hose and clamp.
- Exterior case easily removable for resetting thermostat and field service.
- Q Mount allows unit to hang in place for easy installation.

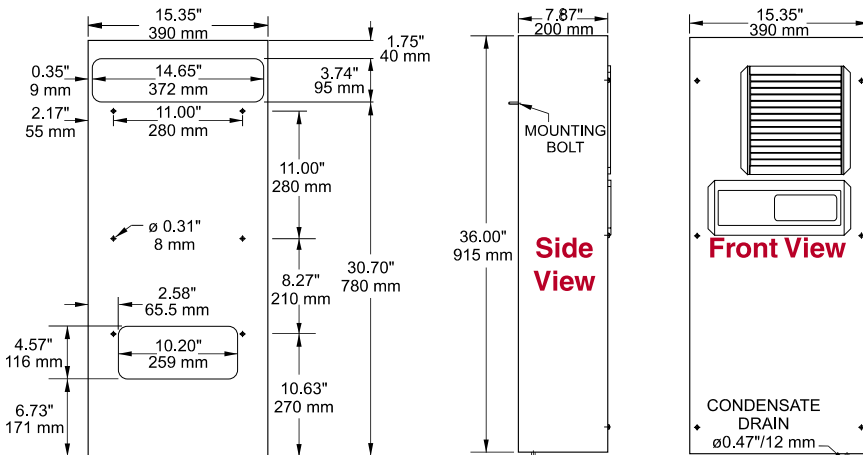

Drilling Template

Note: Any unmarked radius is ϕ 0.79"R

Part Number	Ship Wt. lbs
DTS3500A115LG	99
DTS3500A230LG	99

Technical Data

Electrical Data	DTS3500A115LG	DTS3500A230LG
Rated Voltage	115 V 60 Hz	230 V 50/60 Hz
	110 V 50 Hz	
Range of Operation	103-127 V	207-253 V
Power Consumption	590 W	550 W
Running Amps	6.7 A	2.9 A
Starting Current	17.5 A	8.3 A
Line Cord	With plug	Without plug

Accessories

- Gaskets...see page 400
- Lifting lugs...see page 400
- Remote door switch...see page 400
- Replacement filters...see page 400
- Replacement grill...see page 400

Refrigeration Data

Rated Capacity	3,500 BTU/H (1,014 Watts)
Type of Refrigerant	R134a
Refrigerant Charge	480 g
Adjustable Set Points	Factory setting +95°F (+35°C)
Max. Ambient Air Temp.	+125°F (+52°C)
Min. Ambient Air Temp.	+46°F (+8°C)
Air Capacity (unrestricted)	Internal Circulation 247 CFM External Circulation 341 CFM
Condensate Discharge	Condensate evaporator
Filter Mat	150 g
Db Noise Level	≤ 64 dB(A)
Unit Weight	94 lbs (43 kg)
Exterior Case	Galvanized sheet steel
Finish	RAL7035 light grey finish
NEMA Rating	Enclosures IP 54/NEMA 12

Climate Control

Side Mounting DTS Series

4000 & 7500 BTU/H



7500 BTU/H unit shown

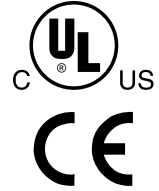

Climate Control

Description

- Designed for side mounting on any enclosure surface where high capacity system cooling is required.
- Closed loop cooling ensures clean enclosure air is recirculated without ever mixing with contaminated ambient air.
- Optimum air circulation with maximum clearance distance between warm inlet and cold outlet for reduced hot spot locations.

Standards

- Maintains enclosure's NEMA 12 rating
- IP 54
- UL, cUL and CE

Features

- R134a refrigerant.
- Thermostat control accessible from inside enclosure.
- Hot gas bypass valve prevents evaporator freeze up while minimizing heavy inrush currents on large BTU/H units.
- Built in condensate evaporator.
- Continuous air circulation from high capacity fans.
- EMI/RFI suppression meets CE.
- Self-diagnostics on startup.
- Fault indication via LED light.
- Provision for door contact allowing power down when enclosure door is opened.
- Gasket, mounting kit and template for enclosure cutout and drilling are included.
- Condensate drain hose and clamp provided.
- Q Mount allows unit to hang in place for easy installation.

Accessories

- Gaskets...see page 400
- Lifting lugs...see page 400
- Remote door switch...see page 400

Technical Data

Part Number	Ship Wt. lbs.
DTS3141A115LG	99
DTS3141A230LG	99
DTS3241A115LG	127
DTS3241A230LG	127

Electrical Data	DTS3141A115LG DTS3141A230LG	DTS3241A115LG DTS3241A230LG
Rated Voltage	115 V 60 Hz/ 230 V 50/60 Hz	115 V 60 Hz/ 230 V 50/60 Hz
Range of Operation	103-127 V/198-252 V	103-127 V/198-252 V
Power Consumption	950 W/860 W	1400 W/1400 W
Running Amps	7.2 A/4.0 A	14.6 A/6.3 A
Starting Current	17.1 A/9.3 A	26.8 A/16.5 A
Line Cord	Terminal Block	Terminal Block

Technical references and DXF downloads available at www.hammmfg.com

All dimensions in inches unless specified otherwise

Side Mounting DTS Series

4000 & 7500 BTU/H

DTS 3141

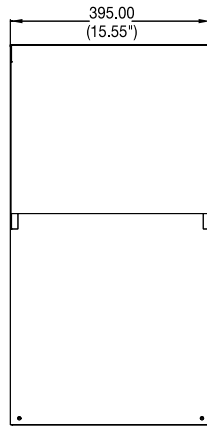

Front View

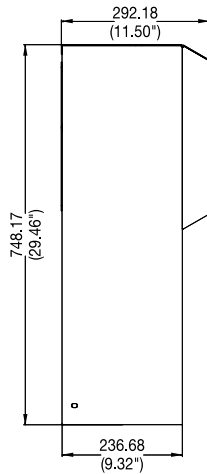

Side View

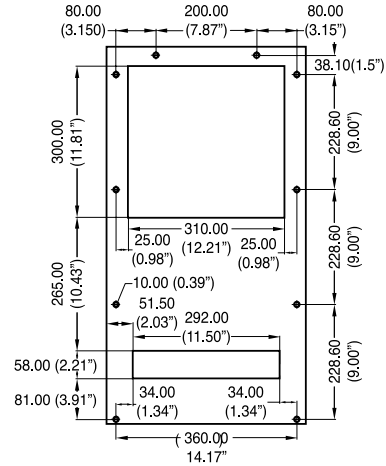

Drilling Template

DTS 3241

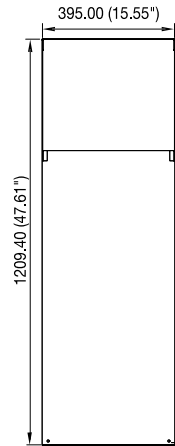

Front View

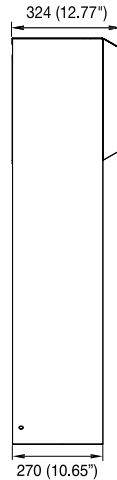

Side View

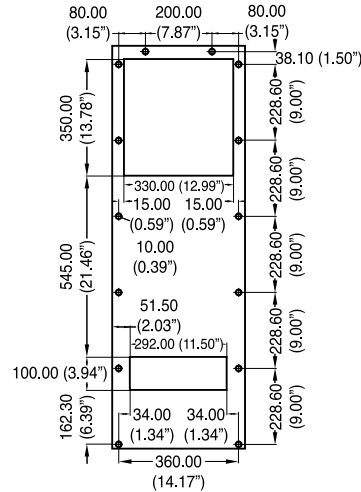

Drilling Template

Climate Control

Refrigeration Data	DTS3141A115/ 230LG	DTS3241A115/ A230LG
Rated Capacity	4,000 BTU/H (1,172 Watts)	7,500 BTU/H (2,197 Watts)
Type of Refrigerant	R134a	R134a
Refrigerant Charge	500 g	500 g
Adjustable Set Points	Factory setting +95°F (+35°C)	Factory setting +95°F (+35°C)
Max. Ambient Air Temp.	+125°F (+52°C)	+125°F (+52°C)
Min. Ambient Air Temp.	+46°F (+8°C)	+46°F (+8°C)
Air Capacity (unrestricted)	Internal Circulation 350 CFM External Circulation 350 CFM	Internal Circulation 580 CFM External Circulation 580 CFM
Condensate Discharge	Condensate Evaporator	Condensate Evaporator
Filter Mat	Filterless	Filterless
Db Noise Level	≤ 70 dB(A)	≤ 73 dB(A)
Unit Weight	80 lbs (36 kg)	101 lbs (46 kg)
Exterior Case	Galvanized sheet steel	Galvanized sheet steel
Finish	RAL7035 Light Grey powder finish	RAL7035 Light Grey powder finish
NEMA Rating	Enclosures IP 54/NEMA 12	Enclosures IP 54/NEMA 12

Technical references and DXF downloads available at www.hamfmfg.com

All dimensions in inches unless specified otherwise

Quality Enclosures. Service Excellence.

Side Mounting DTS Series

8000 & 12000 BTU/H



Description

- Designed for side mounting on any enclosure surface where high capacity system cooling is required.
- Closed loop cooling ensures clean enclosure air is recirculated without ever mixing with contaminated ambient air.
- Optimum air circulation with maximum clearance distance between warm inlet and cold outlet for reduced hot spot locations.

Standards

- Maintains enclosure's NEMA 12 rating
- IP 54
- UR, cUR and CE

Features

- R134a refrigerant.
- Thermostat control.
- Hot gas bypass valve prevents evaporator freeze up while minimizing heavy inrush currents on large BTU/H units.
- Built in condensate evaporator.
- Continuous air circulation from high capacity fans.
- EMI/RFI suppression meets CE.
- Self-diagnostics on startup.
- Fault indication via LED light.
- Provision for door contact allowing power down when enclosure door is opened.
- Gasket, mounting kit and template for enclosure cutout and drilling are included.
- Washable filtermat protected within an easily removable grill.
- Condensate drain hose and clamp provided.
- Q Mount allows unit to hang in place for easy installation.
- Versatile design maintains foot print for larger capacity units if required.

Accessories

- Gaskets...see page 400
- Lifting lugs...see page 400
- Remote door switch...see page 400
- Replacement filters...see page 400
- Replacement grill...see page 400

Technical Data

Part Number	Ship Wt. lbs.
DTS8000A115LG	189
DTS8000A230LG	189
DTS12000A115LG	189
DTS12000A230LG	189

Electrical Data	DTS8000A115LG DTS8000A230LG	DTS12000A115LG DTS12000A230LG
Rated Voltage	115 V 60 Hz/ 230 V 50/60 Hz	115 V 60 Hz/ 230 V 50/60 Hz
Range of Operation	103-127 V/187-253 V	103-127 V/187-253 V
Power Consumption	2,100 W/1,800 W	2,300 W/2,000 W
Running Amps	21.0 A/12.5 A	21.0 A/12.5 A
Starting Current	52.0 A/46.2 A	52.0 A/46.2 A
Line Cord	8' Cord	8' Cord

Technical references and DXF downloads available at www.hammf.com

All dimensions in inches unless specified otherwise

Side Mounting DTS Series

8000 & 12000 BTU/H

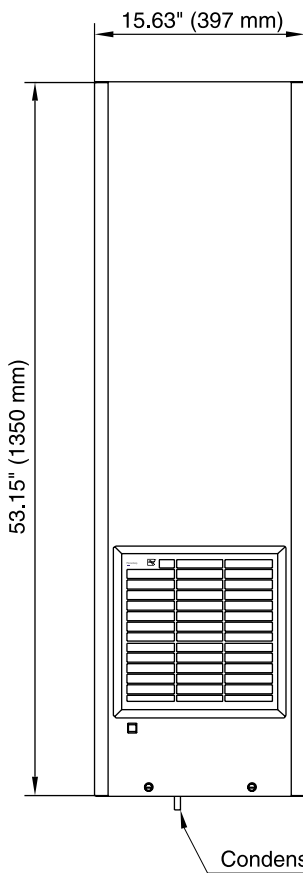

Front View

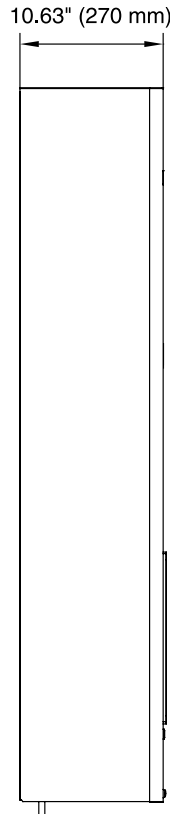

Side View

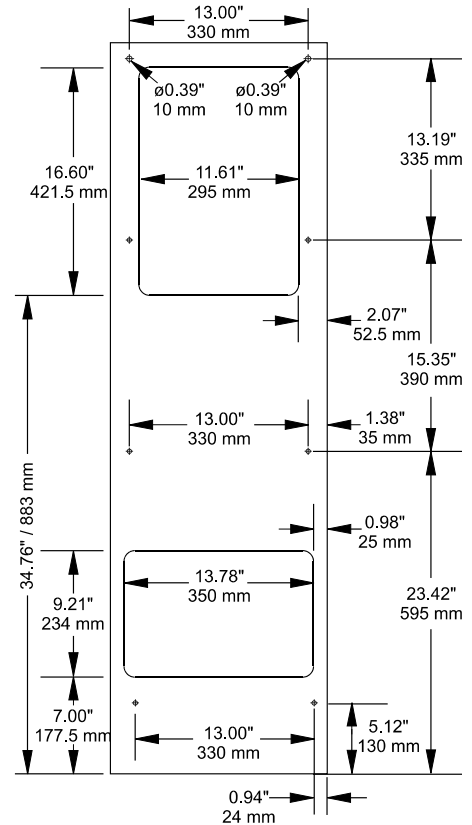

Drilling Template

Climate Control

Refrigeration Data	DTS8000A115LG DTS8000A230LG	DTS12000A115LG DTS12000A230LG
Rated Capacity	8,000 BTU/H (2,340 Watts)	12,000 BTU/H (3,500 Watts)
Type of Refrigerant	R134a	R134a
Refrigerant Charge	750 g	850 g
Adjustable Set Points	Factory setting +95°F (+35°C)	Factory setting +95°F (+35°C)
Max. Ambient Air Temp.	+125°F (+52°C)	+125°F (+52°C)
Min. Ambient Air Temp.	+46°F (+8°C)	+46°F (+8°C)
Air Capacity (unrestricted)	Internal Circulation 450 CFM External Circulation 589 CFM	Internal Circulation 530 CFM External Circulation 589 CFM
Condensate Discharge	Condensate Evaporator	Condensate Evaporator
Filter Mat	150 g/ m ²	150 g/ m ²
Db Noise Level	≤ 69 dB(A)	≤ 69 dB(A)
Unit Weight	160 lbs (72 kg)	165 lbs (75 kg)
Exterior Case	Galvanized sheet steel	Galvanized sheet steel
Finish	RAL7035 Light Grey powder finish	RAL7035 Light Grey powder finish
NEMA Rating	Enclosures IP 54/NEMA 12	Enclosures IP 54/NEMA 12

Side Mounting DTS Series

16,000 BTU/H

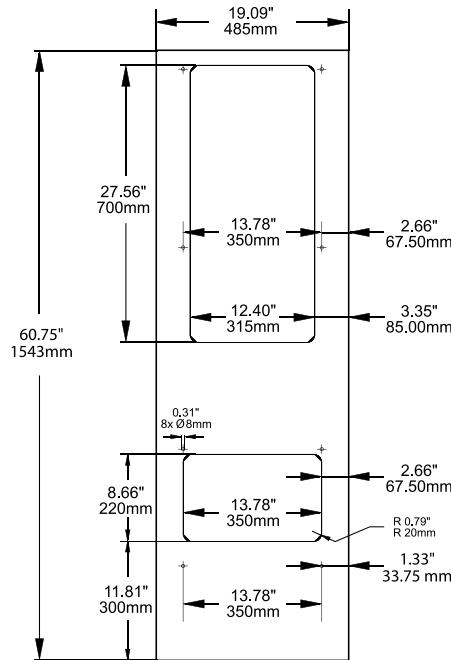

Drilling Template



Description

- Designed for side mounting on any enclosure surface where high capacity system cooling is required.
- Closed loop cooling ensures clean enclosure air is recirculated without ever mixing with contaminated ambient air.

Standards

- Maintains enclosure's NEMA 12 rating
- IP 54
- UR, cUR and CE

Features

- R134a refrigerant.
- Thermostat control accessible from inside enclosure.
- Expansion valve increases efficiency with improved evaporator heat transfer and less frequent compressor operation.
- Direct condensate discharge via drain hose.
- Continuous air circulation from high capacity fans.
- EMI/RFI suppression meets CE.
- Self-diagnostics on startup.
- Fault indication via LED light.
- Door contact for power down when enclosure door is opened.
- Gasket, mounting kit and template for cutout and drilling are included.
- Condensate drain hose and clamp.

Accessories

- Gaskets...see page 400
- Lifting lugs...see page 400
- Remote door switch...see page 400

Climate Control

Part Number	Ship Wt. lbs
DTS9841A460LG	210

Technical Data

Electrical Data	DTS9841A460LG
Rated Voltage	460v 60Hz 3 phase
Range of Operation	380v 50Hz / 460v 60Hz
Power Consumption	1891W / 2336W
Running Amps	4.2A / 3.6A
Starting Current	28.3A / 25.2A
Line Cord	Terminal Block

Refrigeration Data	
Rated Capacity	16,000 BTU/H (4,000 Watts)
Type of Refrigerant	R134a
Refrigerant Charge	2,100 g
Adjustable Set Points	Factory setting +95°F (+35°C)
Max. Ambient Air Temp.	+131°F (+55°C)
Min. Ambient Air Temp.	+59°F (+15°C)
Air Capacity (unrestricted)	Internal Circulation 882 CFM External Circulation 1,076 CFM
Condensate Discharge	Condensate Drain
Filter Mat	Filterless
Db Noise Level	≤ 70 dB(A)
Unit Weight	200 lbs (91 kg)
Exterior Case	Galvanized sheet steel
Finish	RAL7035 light grey finish
NEMA Rating	Enclosures IP 54/NEMA 12

Technical references and DXF downloads available at www.hamfmg.com

All dimensions in inches unless specified otherwise

Top Mounting DTT Series
4500 BTU/H



Description

- Designed for top mounting where space limitations do not allow side mounting on the enclosure surface.
- Closed loop cooling ensures clean enclosure air is recirculated without ever mixing with contaminated ambient air.

Standards

- Maintains NEMA 12 rating
- IP 54
- UR, cUR, CE

Features

- R134a refrigerant.
- Thermostat control.
- Expansion valve increases efficiency with improved evaporator heat transfer and less frequent compressor operation.
- Built in condensate evaporator.
- Continuous air circulation from high capacity fans.
- EMI/RFI suppression meets CE.
- Line cord with plug (115 V).
- Washable filter mat protected within an easily removable grill.
- Gasket, mounting kit and template for cutout and drilling are included.
- Condensate drain hose and clamp.

- Volt free contact for high pressure failure.
- Exterior case easily removable for resetting thermostat and field service.
- Can accommodate crane hooks to assist installation.
- Versatile design maintains foot print through the series.

Accessories

- Gaskets...see page 400
- Lifting lugs...see page 400
- Remote door switch...see page 400
- Replacement filters...see page 400
- Replacement grill...see page 400

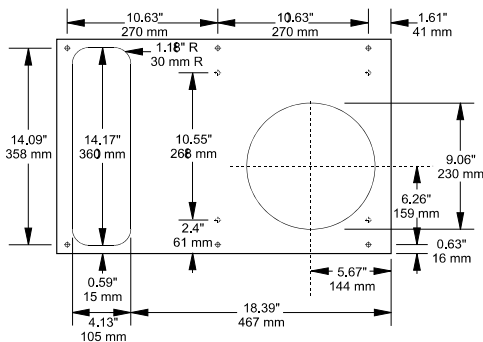

Drilling Template

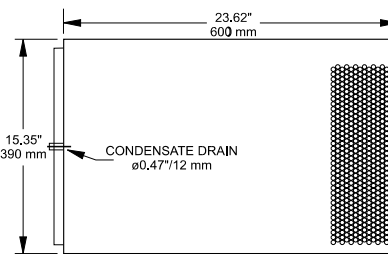

Top View

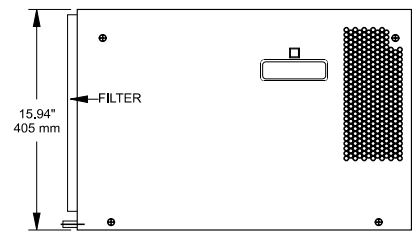

Side View

Part Number	Ship Wt. lbs.
DTT4500A115LG	95
DTT4500A230LG	95

Technical Data

Electrical Data	DTT4500A115LG	DTT4500A230LG
Rated Voltage	115 V 60 Hz	230V 50/60 Hz
	100 V 50 Hz	
Range of Operation	103-127 V	207-253 V
Power Consumption	630 W	840 W
Running Amps	7.7 A	5.2 A
Starting Current	24.9 A	18.5 A
Line Cord	With plug	Without plug

Refrigeration Data

Rated Capacity	4,500 BTU/H (1,300 Watts)
Type of Refrigerant	R134a
Refrigerant Charge	480 g
Adjustable Thermostat	Factory setting +95°F (+35°C)
Max. Ambient Air Temp.	+125°F (+52°C)
Min. Ambient Air Temp.	+46°F (+8°C)
Air Capacity (unrestricted)	Internal Circulation 547 CFM External Circulation 547 CFM
Condensate Discharge	Condensate evaporator
Filter Mat	150 g/m ²
Db Noise Level	≤ 66 dB(A)
Unit Weight	90 lbs (41 kg)
Exterior Case	Galvanized sheet steel
Finish	RAL7032 beige powder finish
NEMA Rating	Enclosures IP 54/NEMA 12

Technical references and DXF downloads available at www.hammfg.com

All dimensions in inches unless specified otherwise

Quality Enclosures. Service Excellence.

Air Conditioner Accessories

Neoprene Gasket Kit

- Replacement for standard supplied gasket.
- Self-adhesive cellular neoprene gasket.
- Supplied in 10 foot rolls, 0.19"x0.75".
- For side mount units greater than 3500 BTU/H, two gasket kits are required.

Part No. **1481DJ10**

Replacement Grill

- Replacement grill for air conditioners.
- Packaged individually.

Black Part No.	RAL 7032 Beige Part No.	Use with Air Conditioner
PG3BK	PG3RAL	DTS1200 - DTS3500
PG5BK	PG5RAL	DTS8000 - DTS12000
n/a	AFF1	DTT4500

Replacement Filters

- Packaged in quantities of 5.
- Made of synthetic fibers.
- Re-usable up to 20 times.
- 100% resistant to humidity.
- Filters have a mass filtering level of 67%.

Part No.	Dimensions		Use With Air Conditioner	Filter Density (g/m ²)
	A	B		
DTSF3150	inch 8.30 mm 210	inch 8.30 mm 210	DTS1200 - DTS6000	150
DTSF5150	inch 11.00 mm 280	inch 11.00 mm 280	DTS8000 - DTS12000	150
DTTF5150	inch 11.81 mm 300	inch 11.81 mm 300	DTT4500	150

Remote Door Switch

- Permits convenient door activated on-off function of air conditioners. Mounts to flange of any Hammond enclosure.
- Can be wired normally open or normally closed.
- 115/230 V AC

Part No. **FLKDS**



Lifting Lugs

- Packaged in quantities of 2.
- Used for lifting, transporting and installation of air conditioners.
- 8 mm diameter.
- For use with DTS3500 - DTS12000 and DTT4500.

Part No. **LL8**

Water Condensate Evaporator



Part No. **KVDTX**

- High performance evaporation kit
- Easy to retrofit on any cooling unit

Technical Data	
Max. Water Volume	13.5 oz (400 ml)
Evaporation Rate	3.4 oz/hr (100 ml/hr)
Electrical Data	
Voltage(s)	230v /115v
Frequency	50/60 Hz
Voltage Range	100-240v
Max. Power	125 W
Power Range	20-110 W
Nominal Current	0.5 A (230v) / 0.8 A (115v)
Starting Current	1.3 A
Zero Water Current	0.09 A (230v) / 0.18 A (115v)
Mechanical Data	
Height x Width x Depth	3.35" x 10.35" x 4.00" (85 x 263 x 102 mm)
Finish	Stainless Steel
Weight	2.6 lbs (1.175 Kg)

Side Mounting DTS Series - NEMA 3R, 4, 4X

2500 BTU/H - Stainless Steel



Description

- Compact design for side mounting on any enclosure surface where spot cooling or low capacity cooling is required.
- Closed loop cooling ensures clean enclosure air is recirculated without ever mixing with contaminated ambient air.
- Ideal for outdoor or very wet conditions.

Standards

- UL, cUL, and CE
- Complies with
 - NEMA 3R, 4, 4X

Features

- Stainless steel body.
- R134a refrigerant.
- Thermostat control.
- Line cord with plug (115 V).
- Expansion valve permits increased efficiency through improved evaporator heat transfer and less frequent compressor operation.
- Continuous air circulation from high capacity fans.
- EMI/RFI suppression meets CE standard.
- Gasket, mounting kit, and template for cutout and drilling are included.
- Direct condensate discharge, drain hose and clamp.
- Q Mount allows unit to hang in place for easy installation.

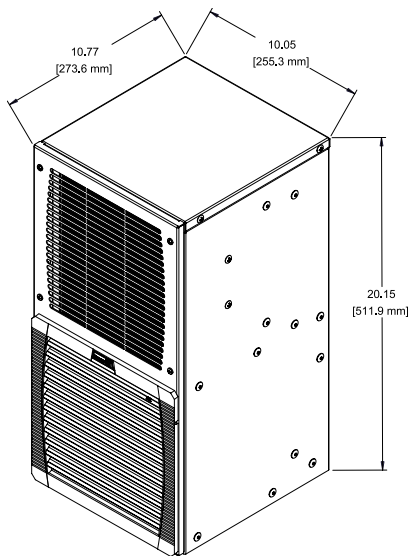

Dimensional Drawing Only

Part Number	Ship Wt. lbs.
DTS3081A115N4SS	60
DTS3081A230N4SS	60

Technical Data

Electrical Data	DTS3081A115N4SS	DTS3081A230N4SS
Rated Voltage	115 V 60 Hz 110 V 50 Hz	230 V 50/60 Hz
Range of Operation	103-127 V	198-253 V
Power Consumption	690 W	724 W
Running Amps	6.0 A	3.3 A
Starting Current	28 A	14.4 A
Line Cord	With plug	With plug

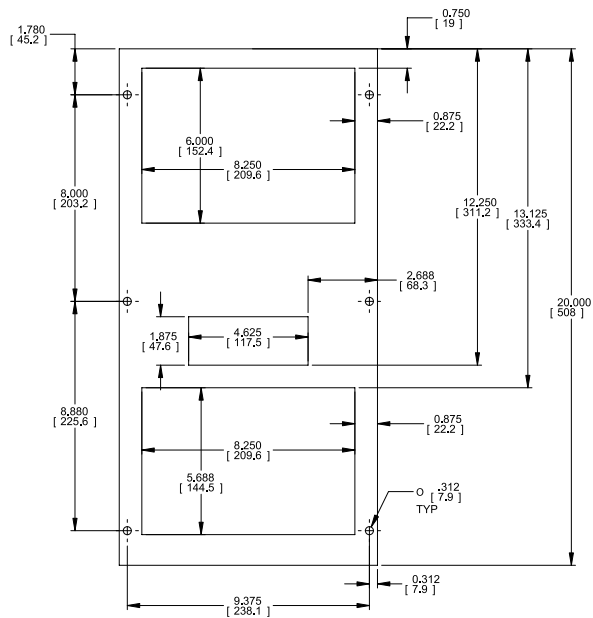

Refrigeration Data

Rated Capacity	2,500 BTU/H (732 Watts)
Type of Refrigerant	R134a
Refrigerant Charge	400 g
Adjustable Thermostat	Factory setting +95°F (+35°C)
Max. Ambient Air Temp.	+131°F (+55°C)
Min. Ambient Air Temp.	+46°F (+8°C)
Air Capacity (unrestricted)	Internal Circulation 191 CFM External Circulation 88 CFM
Condensate Discharge	Condensate drain
Filter Mat	Filterless
Db Noise Level	≤ 64 dB(A)
Unit Weight	55 lbs (25 kg)
Exterior Case	304 Stainless steel
Finish	Polish #3
NEMA Rating	3R, 4, 4X

Climate Control

Side Mounting DTS Series - NEMA 3R, 4

4000 & 7500 BTU/H



4000 BTU/H Shown

Description

- Designed for side mounting on any enclosure surface where high capacity system cooling is required.
- Closed loop cooling ensures clean enclosure air is recirculated without ever mixing with contaminated ambient air.
- Optimum air circulation with maximum clearance distance between warm inlet and cold outlet for reduced hot spot locations.

Standards

- UL, cUL, CE
- Complies with
 - NEMA 3R, 4

Features

- R134a refrigerant.
- Thermostat control accessible from inside enclosure.
- Expansion valve prevents evaporator freeze up while minimizing heavy inrush currents on large BTU/H units.
- Built in condensate evaporator.
- Continuous air circulation from high capacity fans.
- EMI/RFI suppression meets CE.
- Self-diagnostics on startup.
- Fault indication via LED light.
- Provision for door contact allowing power down when enclosure door is opened.
- Gasket, mounting kit and template for enclosure cutout and drilling are included.
- Condensate drain hose and clamp provided.
- Q Mount allows unit to hang in place for easy installation.
- Nema 3R/4 exterior galvanized sheet steel with powdercoat finish.

Climate Control

Part Number	Ship Wt. lbs.
DTS3161A115N3LG	104
DTS3161A230N3LG	104
DTS3261A115N3LG	129
DTS3261A230N3LG	129

Accessories

- Gaskets...see page 400
- Lifting lugs...see page 400
- Remote door switch...see page 400

Technical Data

Electrical Data	DTS3161A115N3LG	DTS3161A230N3LG	DTS3261A115N3LG	DTS3261A230N3LG
Rated Voltage	115 V 60 Hz	230 V 50/60 Hz	115 V 60 Hz	230 V 50/60 Hz
Range of Operation	103-127 V	198-252 V	103-127 V	198-252 V
Power Consumption	950 W	860 W	1800 W	1800 W
Running Amps	7.2 A	4 A	14.6 A	6.3 A
Starting Current	17.1 A	9.3 A	26.8 A	16.5 A
Line Cord	Terminal Block	Terminal Block	Terminal Block	Terminal Block

Side Mounting DTS Series - NEMA 3R, 4

4000 & 7500 BTU/H

DTS 3161

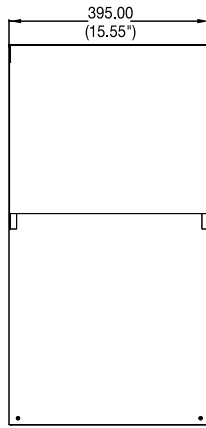

Front View

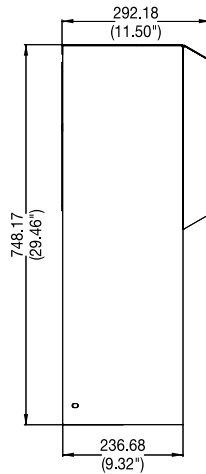

Side View

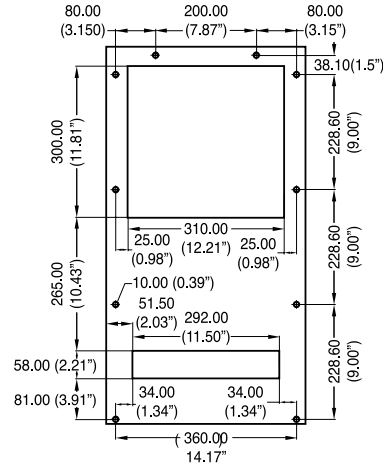

Drilling Template

DTS 3261

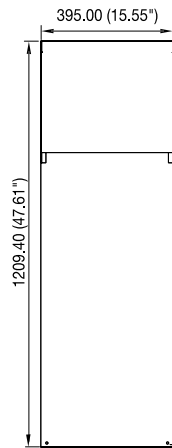

Front View

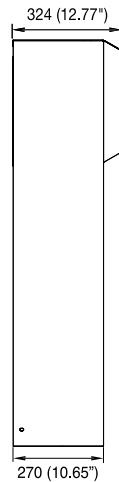

Side View

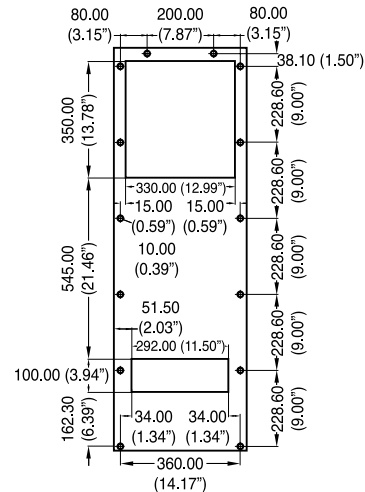

Drilling Template

Climate Control

Refrigeration Data	DTS3161A115/230N3LG	DTS3261A115/230N3LG
Rated Capacity	4,000 BTU/H (1,172 Watts)	7,500 BTU/H (2,197 Watts)
Type of Refrigerant	R134a	R134a
Refrigerant Charge	500 g	500 g
Adjustable Thermostat	Factory setting +95°F (+35°C)	Factory setting +95°F (+35°C)
Max. Ambient Air Temp.	+125°F (+52°C)	+125°F (+52°C)
Min. Ambient Air Temp.	+46°F (+8°C)	+46°F (+8°C)
Air Capacity (unrestricted)	Internal Circulation 350 CFM External Circulation 350 CFM	Internal Circulation 580 CFM External Circulation 580 CFM
Condensate Discharge	Condensate Evaporator	Condensate evaporator
Filter Mat	150 g/m ²	150 g/m ²
Db Noise Level	≤ 70 dB(A)	≤ 73 dB(A)
Unit Weight	84 lbs (38 kg)	120 lbs (46 kg)
Exterior Case	Galvanized Steel Powdercoat Finish	Galvanized Steel Powdercoat Finish
Finish	RAL7035 Light Grey powder finish (LG)	RAL7035 Light Grey powder finish (LG)
NEMA Rating	Enclosures IP56 /NEMA 3R/4	Enclosures IP56 /NEMA 3R/4

Technical references and DXF downloads available at www.hamfmfg.com

All dimensions in inches unless specified otherwise

Quality Enclosures. Service Excellence.

Side Mounting DTS Series - NEMA 3R, 4, 4X

4000 & 7500 BTU/H - Stainless Steel

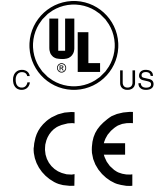

Light Grey 4000 BTU/H Shown

Description

- Designed for side mounting on any enclosure surface where high capacity system cooling is required.
- Closed loop cooling ensures clean enclosure air is recirculated without ever mixing with contaminated ambient air.
- Optimum air circulation with maximum clearance distance between warm inlet and cold outlet for reduced hot spot locations.

Standards

- UL, cUL, CE
- Complies with
 - NEMA 3R, 4, 4X

Features

- R134a refrigerant.
- Thermostat control accessible from inside enclosure.
- Expansion valve prevents evaporator freeze up while minimizing heavy inrush currents on large BTU/H units.
- Built in condensate evaporator.
- Continuous air circulation from high capacity fans.
- EMI/RFI suppression meets CE.
- Self-diagnostics on startup.
- Fault indication via LED light.
- Provision for door contact allowing power down when enclosure door is opened.
- Gasket, mounting kit and template for enclosure cutout and drilling are included.
- Condensate drain hose and clamp provided.
- Q Mount allows unit to hang in place for easy installation.
- Nema 4/4x exterior 304 stainless steel.

Accessories

- Gaskets...see page 400
- Lifting lugs...see page 400
- Remote door switch...see page 400

Climate Control

Part Number	Ship Wt. lbs.
DTS3181A115N4SS	107
DTS3181A230N4SS	107
DTS3281A115N4SS	144
DTS3281A230N4SS	144

Technical Data

Electrical Data	DTS3181A115N4SS	DTS3181A230N4SS	DTS3281A115N4SS	DTS3281A230N4SS
Rated Voltage	115 V 60 Hz	230 V 50/60 Hz	115 V 60 Hz	230 V 50/60 Hz
Range of Operation	103-127 V	198-252 V	103-127 V	198-252 V
Power Consumption	950 W	860 W	1800 W	1800 W
Running Amps	7.2 A	4 A	14.6 A	6.3 A
Starting Current	17.1 A	9.3 A	26.8 A	16.5 A
Line Cord	Terminal Block	Terminal Block	Terminal Block	Terminal Block

Technical references and DXF downloads available at www.hamfmfg.com

All dimensions in inches unless specified otherwise

Side Mounting DTS Series - NEMA 3R, 4, 4X

4000 & 7500 BTU/H - Stainless Steel

DTS 3181

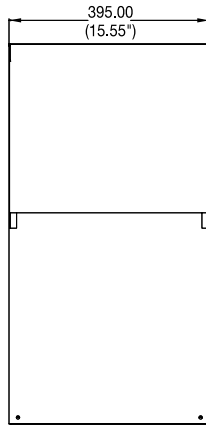

Front View

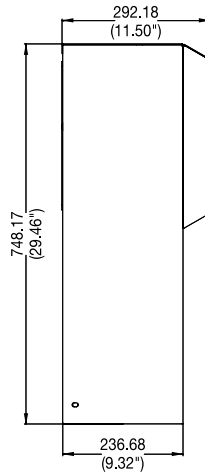

Side View

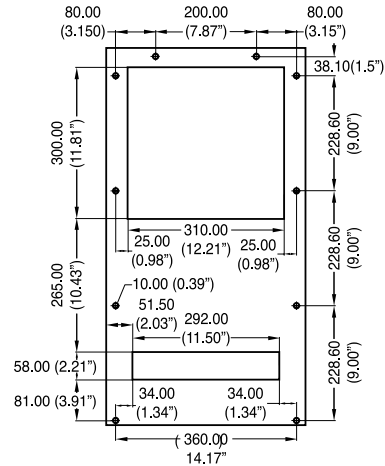

Drilling Template

DTS 3281

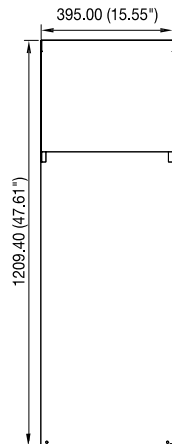

Front View

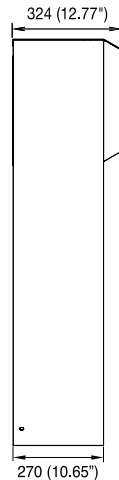

Side View

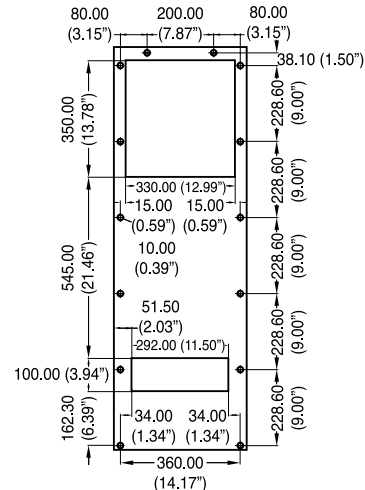

Drilling Template

Climate Control

Refrigeration Data	DTS3181A115/230N4SS	DTS3281A115/230N4SS
Rated Capacity	4,000 BTU/H (1,172 Watts)	7,500 BTU/H (2,197 Watts)
Type of Refrigerant	R134a	R134a
Refrigerant Charge	500 g	500 g
Adjustable Thermostat	Factory setting +95°F (+35°C)	Factory setting +95°F (+35°C)
Max. Ambient Air Temp.	+125°F (+52°C)	+125°F (+52°C)
Min. Ambient Air Temp.	+46°F (+8°C)	+46°F (+8°C)
Air Capacity (unrestricted)	Internal Circulation 350 CFM External Circulation 350 CFM	Internal Circulation 580 CFM External Circulation 580 CFM
Condensate Discharge	Condensate Evaporator	Condensate evaporator
Filter Mat	150 g/m ²	150 g/m ²
Db Noise Level	≤ 70 dB(A)	≤ 73 dB(A)
Unit Weight	84 lbs (38 kg)	120 lbs (46 kg)
Exterior Case	304 Stainless Steel	304 Stainless Steel
Finish	Polish #3	Polish #3
NEMA Rating	Enclosures IP56 /NEMA 3R/4x	Enclosures IP56 /NEMA 3R/4x

Technical references and DXF downloads available at www.hamfmfg.com

All dimensions in inches unless specified otherwise

Quality Enclosures. Service Excellence.