

THIS DOCUMENT CONTAINS DATA PROPRIETARY TO PROJECTS UNLIMITED, INC. ANY USE OR REPRODUCTION, IN ANY FORM, WITHOUT PRIOR WRITTEN PERMISSION OF PROJECTS UNLIMITED, INC. IS PROHIBITED.  
© 2003, Projects Unlimited Inc.

SPECIFICATIONS

PARAMETERS	VALUES	UNITS
RATED VOLTAGE (SQUARE WAVE)	10	Vp-p
OPERATING VOLTAGE RANGE	1 ~ 50	Vp-p
RATED CURRENT (MAX)	11	mA
CAPACITANCE	18,000±30%	pF
MINIMUM SPL @ 10 CM	97	dB
RESONANT FREQUENCY	4,500±500	Hz
OPERATING TEMPERATURE	-30 ~ +85	°C
STORAGE TEMPERATURE	-40 ~ +95	°C
HOUSING MATERIAL	ABS	-
TERMINAL MATERIAL	LEAD WIRE	-
WEIGHT	4.7	grams

REVISIONS			
LTR	DESCRIPTION	DATE	APPROVED
-	RELEASED FROM ENGINEERING	5/14/02	
A	REVISED TO NEW TEMPLATE	6/15/04	R. W.

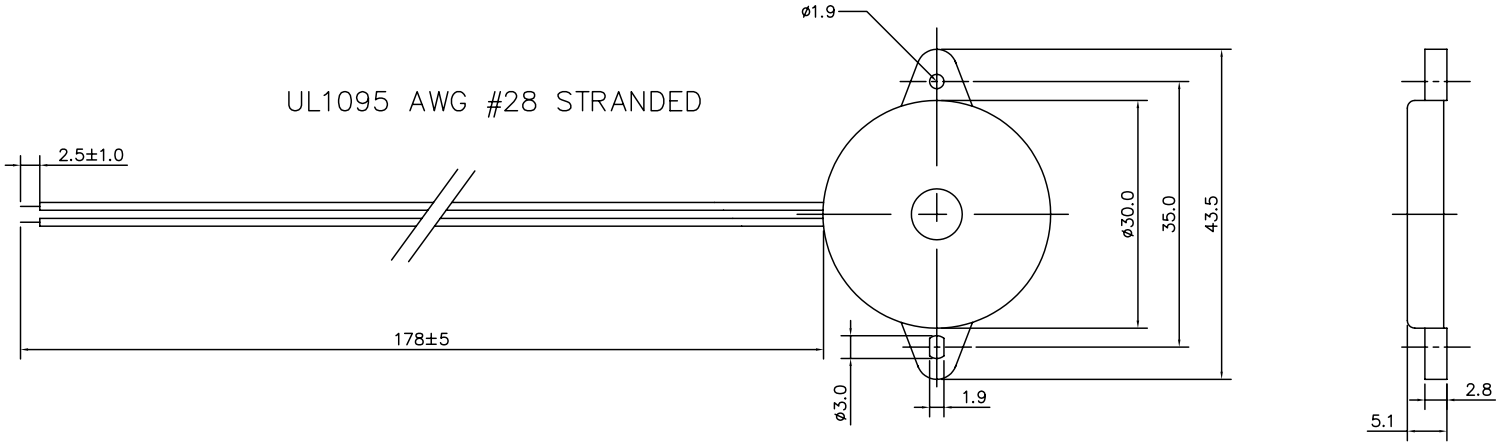

NOTES:

1. ALL DIMENSIONS ARE IN MILLIMETERS.
2. SPECIFICATION SUBJECT TO CHANGE OR WITHDRAWAL WITHOUT NOTICE.
3. WIRE COLOR CODE: RED, BLACK.

FILE NAME  
AT-15-LW178-109528.DWG

UNLESS OTHERWISE SPECIFIED: DIMENSIONS ARE IN MILLIMETERS; TOLERANCES ARE ±0.5 AND ANGLES ARE ±3°.		<b>projects® unlimited</b> Dayton, Ohio	
APPROVALS DRAWN <i>RABL</i> 5/02 APPROVED <i>S.J.</i> 6/02		TRANSDUCER(ELECTRO-MECH) AT-15-LW178-109528	
DO NOT SCALE DRAWING		SIZE A	DRAWING NO. AT-15-LW178-109528
		SCALE: N.T.S.	SHEET 1 OF 1