

THIS DOCUMENT CONTAINS DATA PROPRIETARY TO PROJECTS UNLIMITED, INC. ANY USE OR REPRODUCTION, IN ANY FORM, WITHOUT PRIOR WRITTEN PERMISSION OF PROJECTS UNLIMITED, INC. IS PROHIBITED.
 ©2005, Projects Unlimited Inc.

REVISIONS			
LTR	DESCRIPTION	DATE	APPROVED
-	RELEASED FROM ENGINEERING	1/15/07	

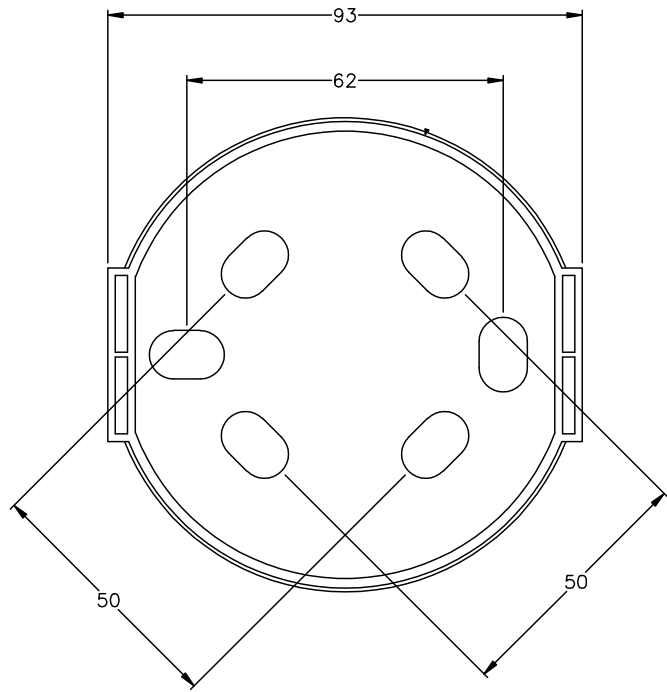
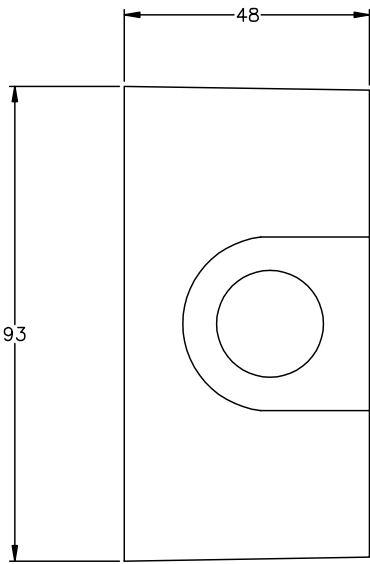

NOTES:

1. ALL DIMENSIONS ARE IN MILLIMETERS.
2. SPECIFICATION SUBJECT TO CHANGE OR WITHDRAWAL WITHOUT NOTICE.

UNLESS OTHERWISE SPECIFIED:
 DIMENSIONS ARE IN MILLIMETERS.TOLERANCES ARE ±0.5 AND ANGLES ARE ±3°.

 projects® unlimited Dayton, Ohio

DEEP BASE

APPROVALS	DATE
DRAWN J.D.	1/07
CHECKED D.F.	1/07
APPROVED B.R.	1/07

SIZE A	DRAWING NO. AWA-DBR
--------	---------------------

FILE NAME
 AWA-DBR.dwg

DO NOT SCALE DRAWING SCALE: N.T.S. SHEET 1 OF 1