

THIS DOCUMENT CONTAINS DATA PROPRIETARY TO PROJECTS UNLIMITED, INC. ANY USE OR REPRODUCTION, IN ANY FORM, WITHOUT PRIOR WRITTEN PERMISSION OF PROJECTS UNLIMITED, INC. IS PROHIBITED.
© 2003, Projects Unlimited Inc.

SPECIFICATIONS

| PARAMETERS | VALUES | UNITS |
|-----------------------------|-----------------|-------|
| RATED VOLTAGE (SQUARE WAVE) | 10 | Vp-p |
| OPERATING VOLTAGE RANGE | 1 ~ 30 | Vp-p |
| RATED CURRENT (MAX) | 3.5 | mA |
| CAPACITANCE | 20,000±30% | pF |
| MINIMUM SPL @ 10 CM | 88 | dBA |
| RESONANT FREQUENCY | 2,048±500 | Hz |
| OPERATING TEMPERATURE | -20 ~ +60 | °C |
| STORAGE TEMPERATURE | -30 ~ +70 | °C |
| HOUSING MATERIAL | ABS | - |
| TERMINAL MATERIAL | PHOSPHOR BRONZE | - |
| WEIGHT | 2 | grams |

REVISIONS

| LTR | DESCRIPTION | DATE | APPROVED |
|-----|----------------------------------|----------|----------|
| - | RELEASED FROM ENGINEERING | 4/16/02 | |
| A | REVISED TO NEW TEMPLATE | 6/15/04 | R. W. |
| B | REVISED DIMENSION SIZE AND STYLE | 12/19/05 | B. R. |

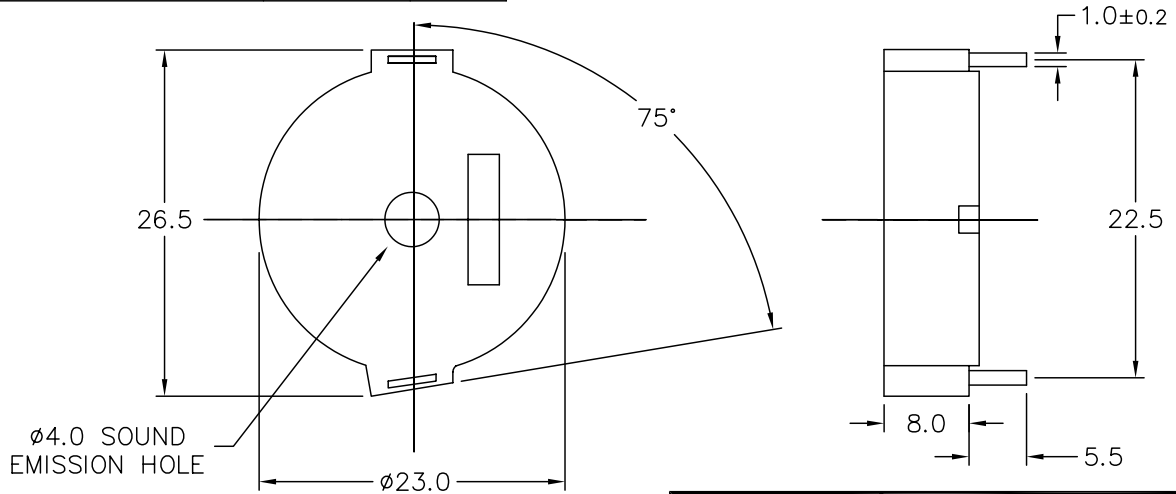

NOTES:

1. ALL DIMENSIONS ARE IN MILLIMETERS.
2. SPECIFICATION SUBJECT TO CHANGE OR WITHDRAWAL WITHOUT NOTICE.

FILE NAME
AT-2220-1.DWG

UNLESS OTHERWISE SPECIFIED:
DIMENSIONS ARE IN MILLIMETERS; TOLERANCES ARE ±0.5 AND ANGLES ARE ±3°.

| APPROVALS | DATE |
|----------------------|------|
| DRAWN <i>RABL</i> | 4/02 |
| APPROVED <i>S.J.</i> | 4/02 |
| DO NOT SCALE DRAWING | |

projects® unlimited Dayton, Ohio

TRANSDUCER(ELECTRO-MECH)

SIZE A DRAWING NO. AT-2220-1

SCALE: N.T.S.

SHEET 1 OF 1