

SPECIFICATIONS

PARAMETERS	VALUES	UNITS
RATED VOLTAGE	110	Vdc
OPERATING VOLTAGE RANGE	70 ~ 150	Vdc
RATED CURRENT (MAX)	25	mA
MINIMUM SPL @ 10 CM	80	dBA
RESONANT FREQUENCY	400 ± 100	Hz
TONE OR PULSE RATE	CONTINUOUS	0 pulse /sec
OPERATING TEMPERATURE	-20 ~ +60	°C
STORAGE TEMPERATURE	-30 ~ +70	°C
HOUSING MATERIAL	PBT	-
TERMINAL MATERIAL	Sn PLATED BRASS	-
WEIGHT	18	grams

THIS DOCUMENT CONTAINS DATA PROPRIETARY TO PROJECTS UNLIMITED, INC. ANY USE OR REPRODUCTION, IN ANY FORM, WITHOUT PRIOR WRITTEN PERMISSION OF PROJECTS UNLIMITED, INC. IS PROHIBITED. ©2003, Projects Unlimited Inc.

REVISION HISTORY

LTR	DESCRIPTION	DATE	APPROVED
-	RELEASED FROM ENGINEERING	5/31/2007	
A	REVISED RESONANT FREQUENCY AND COIL RESISTANCE	9/7/2007	R.W.
B	REVISED RESONANT FREQUENCY AND COIL RESISTANCE	9/26/2007	B.R.
C	REVISED TO INVENTOR 3-D DRAWING TEMPLATE	1/31/2008	B.R.

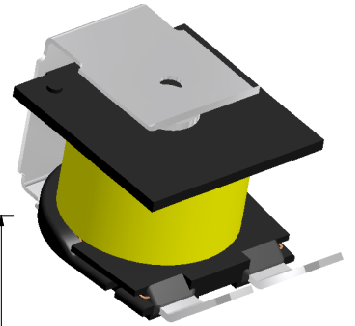
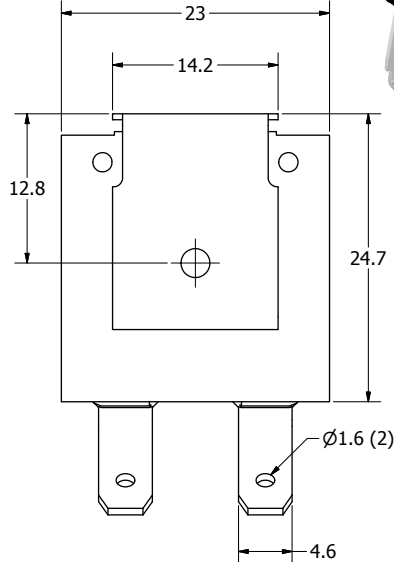
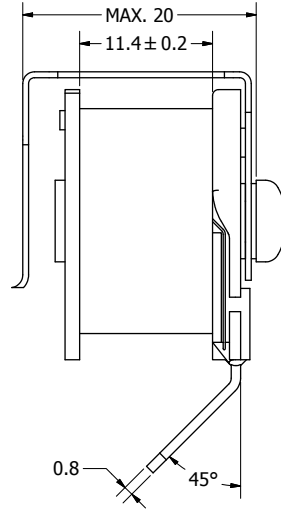
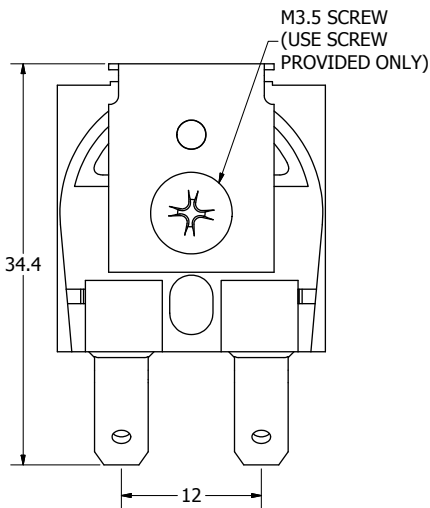

NOTES:

1. ALL DIMENSIONS ARE IN MILLIMETERS.
2. SPECIFICATIONS SUBJECT TO CHANGE OR WITHDRAWAL WITHOUT NOTICE.
3. THIS PART IS RoHS 2002/95/EC COMPLIANT.
4. MOUNTING SCREW PROVIDED.

UNLESS OTHERWISE SPECIFIED: DIMENSIONS ARE IN MILLIMETERS, TOLERANCES ARE ±0.5 AND ANGLES ARE ±3°.	SIZE	Designed by	Date	Checked by	Date	Approved by	Date	Drawn Date	
	A3	J.D.	5/31/2007	D.F.	6/1/2007	R.W.	6/1/2007	1/31/2008	
AI-2505-T-110-R.idw		 pui audio <small>a projects unlimited company</small>		AI-2505-T-110-R				Indicator	
							Edition	Sheet	
							-	1 / 1	