

THIS DOCUMENT IS THE PROPERTY OF  
KEYSTONE ELECTRONICS CORP. AND  
SHALL NOT BE REPRODUCED, DISTRIBUTED  
OR USED AS A BASIS FOR MANUFACTURE  
WITHOUT PRIOR WRITTEN PERMISSION  
FROM KEYSTONE ELECTRONICS CORP.

**MOUNTING DETAIL**

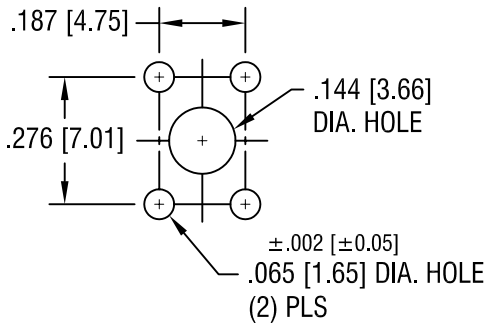

6-32 x 1/4 L.  
CAPTIVATED SCREW

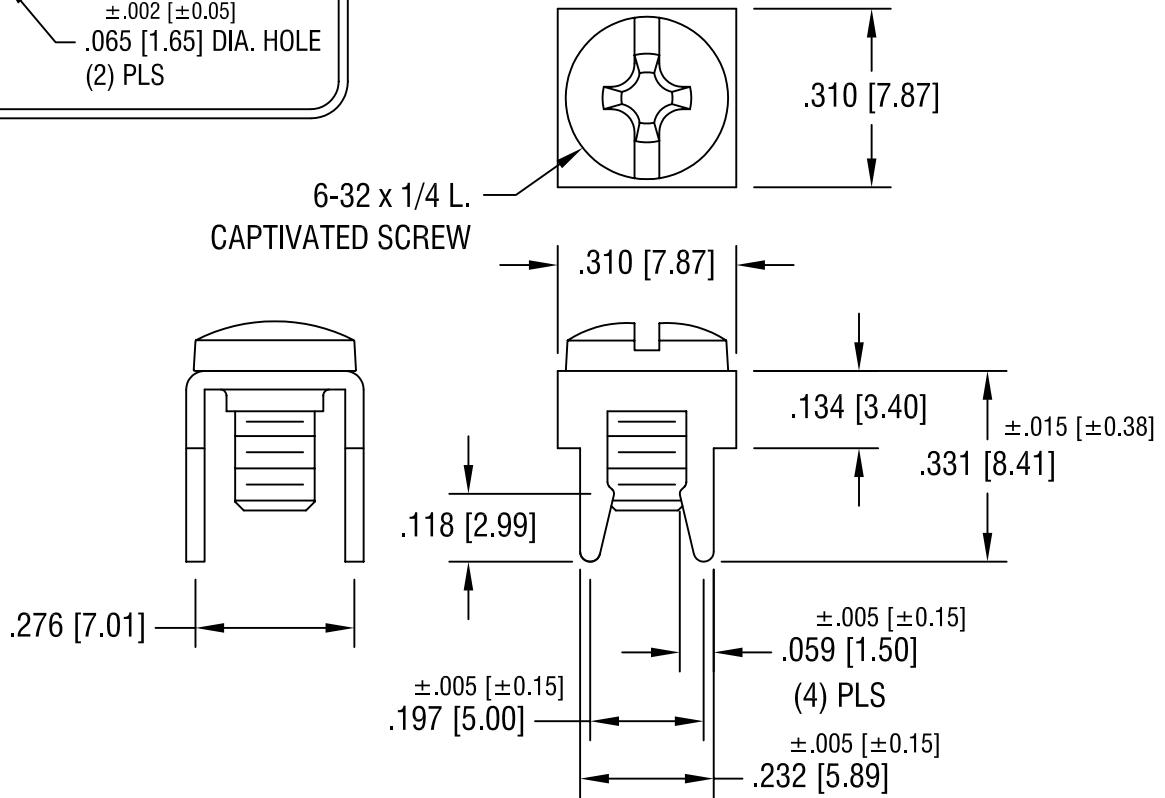

**LOW-PROFILE PC SCREW TERMINAL W/ COLORED SCREW HEAD**

**NOTES:**

- 1. TERMINAL:  
MAT'L - .032 [0.81] TH'K BRASS, TIN PLATE
- SCREW:  
MAT'L - BRASS, NICKEL PLATE

| PART NO. | HEAD COLOR | PART NO. | HEAD COLOR |
|----------|------------|----------|------------|
| 7775-2   | RED        | 7775-5   | BLUE       |
| 7775-3   | BLACK      | 7775-6   | GREEN      |
| 7775-4   | WHITE      | 7775-7   | YELLOW     |

**KEYSTONE ELECTRONICS CORP.**

ASTORIA, N.Y. 11105-2017

PART NAME  
LOW-PROFILE TERM. W/ COLORED SCREW HEAD

MATERIAL  
AS NOTED

|                    |        |       |       |         |
|--------------------|--------|-------|-------|---------|
| FINISH<br>AS NOTED | DRN BY | BOONE | DATE  | 10.1.03 |
|                    | APP'D  |       | SCALE | 3X      |

|        |                          |   |
|--------|--------------------------|---|
| 1.7.08 | CHANGE AS PER ECN 08-037 | A |
|--------|--------------------------|---|

|                            |       |         |      |                 |
|----------------------------|-------|---------|------|-----------------|
| TOLERANCES                 | INCH  | [MM]    | CODE | DWG NO.         |
| DECIMAL                    | ±.010 | [±0.25] | C    | 7775-2 - 7775-7 |
| ANGULAR                    | ± 1°  |         |      |                 |
| UNLESS OTHERWISE SPECIFIED |       |         |      |                 |