

THIS DOCUMENT IS THE PROPERTY OF KEYSTONE ELECTRONICS CORP. AND SHALL NOT BE REPRODUCED, DISTRIBUTED OR USED AS A BASIS FOR MANUFACTURE WITHOUT PRIOR WRITTEN PERMISSION FROM KEYSTONE ELECTRONICS CORP.

MOUNTING DETAIL

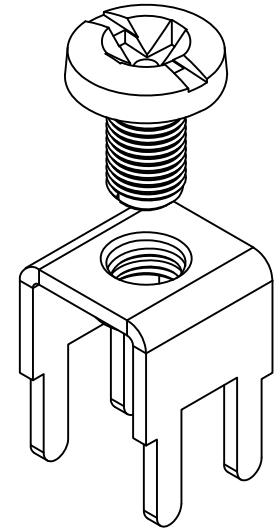
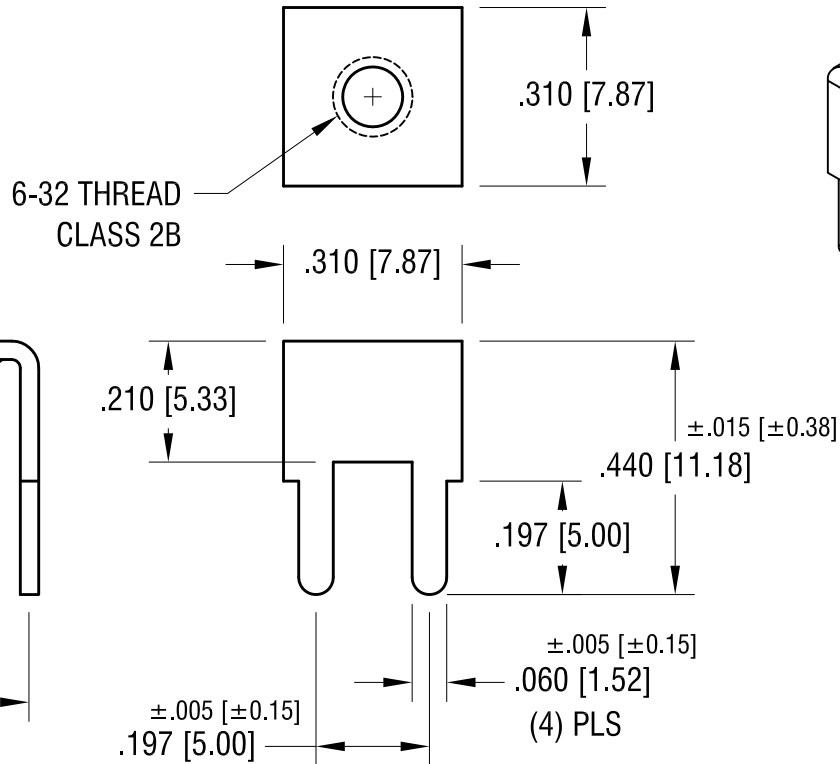
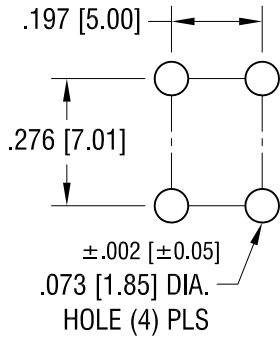

PC SCREW TERMINAL WITH COLORED SCREW HEAD

PART NO.	HEAD COLOR	PART NO.	HEAD COLOR
8191-2	RED	8191-5	BLUE
8191-3	BLACK	8191-6	GREEN
8191-4	WHITE	8191-7	YELLOW

NOTE:

- 1. TERMINAL:
 MAT'L - .032 [0.81] TH'K BRASS, MATTE TIN PLATE
 SCREW : ONE (1) 6-32 x 1/4 L., SUPPLIED LOOSE.
 MAT'L - BRASS, NICKEL PLATE

DATE	DESCRIPTION	REV.
7.13.09	CHANGE AS PER ECN 09-099	B
1.3.08	CHANGE AS PER ECN 08-023	A

KEYSTONE ELECTRONICS CORP.
 www.keyelco.com • ASTORIA, N.Y. 11105-2017 • Tel (718) 956-8900

PART NAME
PC SCREW TERM. W/ COLORED SCREW HEAD

MATERIAL
AS NOTED

FINISH AS NOTED	DRN BY	BOONE	DATE	10.1.03
	APP'D		SCALE	3X

TOLERANCES INCH [MM]	CODE	DWG NO.
DECIMAL ±.010 [±0.25]	C	8191-2 - 8191-7
ANGULAR ± 1° UNLESS OTHERWISE SPECIFIED		