

IBS IL 24 BK-T/U

Order No.: 2742094

The illustration shows a product version of the article

<http://eshop.phoenixcontact.de/phoenix/treeViewClick.do?UID=2742094>

INTERBUS bus coupler, copper connection, 24 V DC, without accessories



Commercial data

GTIN (EAN)	
sales group	K410
Pack	1 pcs.
Customs tariff	85389091
Catalog page information	Page 39 (AX-2007)

Product notes

WEEE/RoHS-compliant since:
11/20/2007

<http://www.download.phoenixcontact.com>
Please note that the data given here has been taken from the online catalog. For comprehensive information and data, please refer to the user documentation. The General Terms and Conditions of Use apply to Internet downloads.

Product description

The INTERBUS bus terminal module connects the terminals of an Inline station with the INTERBUS network. A copper cable or fiber optic cable can be used to couple it to the INTERBUS remote bus. The connection is made accordingly via an INTERBUS Inline shield connector (copper). The bus terminal module takes on the following functions within an Inline station:

- Termination and refreshing of INTERBUS remote bus signals
- Decoupling the outgoing remote bus or the connected input/output modules using a software command
- Supplying the connected input/output modules using an integrated power supply unit

– Connection to functional earth ground when installed on the DIN rail

The Inline terminals can be labeled using hinged labeling fields. The fields have insert cards that can be labeled individually to suit the application. Additionally, there is the ZB-FM-6... Zack marker strip for labeling the terminal points.

Please note the following when you configure the system:

The total logic current of all terminals connected to an Inline bus terminal module must not exceed the maximum permissible total current of 2 A. Therefore, depending on your configuration, the number of terminals that you can connect may be less than 63.

Technical data

Interface

Fieldbus system	Lokalbus
Name	Inline local bus
Connection method	Inline data jumper
Transmission speed	500 kBaud
Fieldbus system	INTERBUS
Name	INTERBUS remote bus
Connection method	2x 6-pos. Inline shield connectors
Transmission speed	500 KBit/s
Transmission physics	Copper
Name	Supply
Connection method	8-pos. Inline connector

Power supply for module electronics

Connection method	Inline connectors
Supply voltage	24 V DC (via Inline connector)
Supply voltage range	19.2 V DC ... 30 V DC (including ripple)
Current consumption	max. 1.25 A (with max. number of connected I/O terminal blocks)

General data

Width	48.8 mm
Height	119.8 mm
Depth	71.5 mm
Weight	142 g
Mounting type	DIN rail
Ambient temperature (operation)	-25 °C ... 55 °C
Ambient temperature (storage/transport)	-25 °C ... 85 °C
Permissible humidity (operation)	75 % ... 85 % (in the range of -25°C ... +55°C, appropriate measures against increased humidity (> 85%) must be taken.)

Permissible humidity (storage/transport)	75 % ... 85 % (Slight temporary condensation may sometimes appear on the housing, e.g. when the terminal block is brought out of a vehicle into an enclosed room.)
Air pressure (operation)	80 kPa ... 106 kPa (up to 3000 m above sea level)
Air pressure (storage/transport)	70 kPa ... 106 kPa (up to 3000 m above sea level)
Degree of protection	IP20
Test section	5 V supply, incoming remote bus/5 V supply outgoing remote bus 500 V AC 50 Hz 1 min
	5 V supply, incoming remote bus/7.5 V logics supply, 24 V analog supply, 24 V bus terminal module supply 500 V AC 50 Hz 1 min
	5 V supply, incoming remote bus/24 V main supply, 24 V segment supply 500 V AC 50 Hz 1 min
	5 V supply incoming remote bus / functional earth ground 500 V AC 50 Hz 1 min
	5 V supply, outgoing remote bus/24 V main supply, 24 V segment supply 500 V AC 50 Hz 1 min
	5 V supply, outgoing remote bus/7.5 V logics supply, 24 V analog supply, 24 V bus terminal module supply 500 V AC 50 Hz 1 min
	5 V supply outgoing remote bus / functional earth ground 500 V AC 50 Hz 1 min
	7.5 V logics supply, 24 V analog supply, 24 V bus terminal module supply/functional earth ground 500 V AC 50 Hz 1 min
	7.5 V logics supply, 24 V analog supply, 24 V bus terminal module supply / 24 V main supply, 24 V segment supply 500 V AC 50 Hz 1 min
	24 V main supply, 24 V segment supply/functional earth ground 500 V AC 50 Hz 1 min
Inline potential routing	
Communications power U_L	7.5 V DC $\pm 5\%$
Power supply at U_L	max. 2 A DC (observe derating)
Main circuit supply U_M	24 V DC -15% / +20% (in acc. with EN 61131-2)
Power supply at U_M	max. 8 A (Sum of $U_M + U_S$)
Segment supply voltage U_S	24 V DC -15% / +20% (in acc. with EN 61131-2)
Power supply at U_S	max. 8 A (Sum of $U_M + U_S$)
I/O supply voltage U_{ANA}	24 V DC -15% / +20%
Power supply at U_{ANA}	max. 0.5 A DC (observe derating)

Certificates / Approvals



Certification ABS, BV, CUL, DNV, GL, GOST, LR, UL
 Certification Ex: CUL-EX LIS, PxC-EX, UL-EX LIS

Accessories

Item	Designation	Description
Assembly		
1201442	E/UK	End clamp, for assembly on NS 32 or NS 35/7.5 DIN rail
Marking		
0809492	ESL 62X10	Insert strip for laser printer, lettering field: 62 x 10 mm
2727501	IB IL FIELD 2	Labeling field, width: 12.2 mm
Plug/Adapter		
2860374	IB IL BK-PLSET/CP	Connector set for Inline bus coupler, color-coded

Diagrams/Drawings

Connection diagram

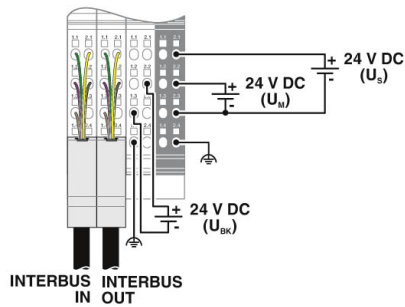

Block diagram

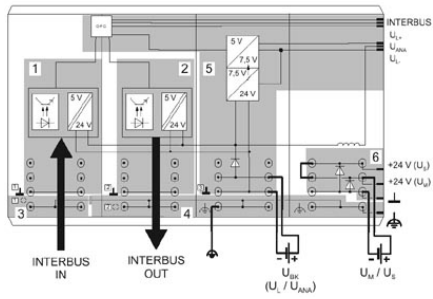

Dimensioned drawing

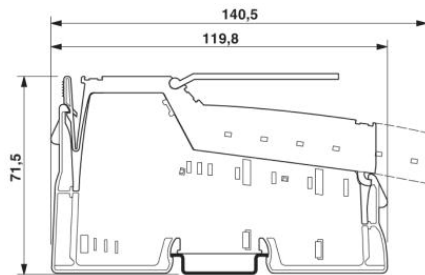

Address

PHOENIX CONTACT Inc., USA
586 Fulling Mill Road
Middletown, PA 17057, USA
Phone (800) 888-7388
Fax (717) 944-1625
<http://www.phoenixcon.com>



© 2011 Phoenix Contact
Technical modifications reserved;