

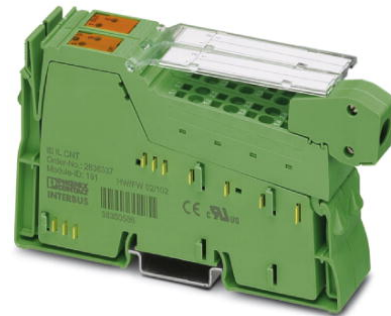

IB IL CNT-PAC

Order No.: 2861852

<http://eshop.phoenixcontact.de/phoenix/treeViewClick.do?UID=2861852>

Inline counter terminal block, complete with accessories (connector and labeling field), 1 counter input, 1 control input, 1 output, 24 V DC, 500 mA, 3-wire connection method

Commercial data	
GTIN (EAN)	 4 017918 894559
sales group	K413
Pack	1 pcs.
Customs tariff	85389091
Catalog page information	Page 216 (AX-2011)

Product notes

WEEE/RoHS-compliant since:
09/25/2007



<http://www.download.phoenixcontact.com>
Please note that the data given here has been taken from the online catalog. For comprehensive information and data, please refer to the user documentation. The General Terms and Conditions of Use apply to Internet downloads.

Product description

The Inline IB IL CNT counter terminal registers and processes quick pulse trains from sensors. It has a counter input, a control input, and a switching output that can be parameterized by the module itself. This way, quick response times can be achieved independent of the bus and the control system.

The module can be operated in different operating modes:

- Event counting

- Time measurement and
- Pulse generation

The inputs can be used to connect initiators with 24 V DC supply and 5 V DC supply. The switching output supplies a maximum current of 500 mA.

The Inline counter terminals can be labeled using hinged labeling fields. The fields have insert cards that can be labeled individually to suit the application. Additionally, there is the ZB-FM-6... Zack strip for labeling the terminal points.

Technical data

General data

Weight	130 g
Number of connectors	2
Degree of protection	IP20
Protection class	III, IEC 61140, EN 61140, VDE 0140-1
Connection data	Inline connectors Spring-cage connection 0.08 mm ² 1.5 mm ² 0.08 mm ² 1.5 mm ² 28 16
Width	24.4 mm
Height	135 mm
Depth	71.5 mm

Interfaces

Interface	Inline local bus
Connection method	Inline data jumper
Transmission speed	500 kBit/s
Transmission physics	Copper

Power supply

Communications power U _L	7.5 V DC (via voltage jumper)
Max. current consumption	50 mA
Typical current consumption	40 mA
I/O voltage	24 V DC (via voltage jumper)
Ripple	5 %
Peripherals voltage range	19.2 V DC ... 30 V DC (including all tolerances, including ripple)
Initiator power supply	Segment circuit (500 mA)
Comments	The following are connected to the segment circuit U _S : Switching output, sensor supplies with their own short-circuit protection

Electrical isolation

Test section	5 V supply, incoming remote bus/7.5 V supply (bus logics) 500 V AC 50 Hz 1 min
	5 V supply, outgoing remote bus/7.5 V supply (bus logics) 500 V AC 50 Hz 1 min
	7.5 V supply (bus logics)/24 V supply (I/O) 500 V AC 50 Hz 1 min
	24 V supply (I/O) / functional earth ground 500 V AC 50 Hz 1 min

Counter input

Number of inputs	2
Operating mode	Event counting, frequency/time measurement, pulse generator
Input frequency	max. 100 kHz
Input voltage	24 V DC
	5 V DC
Input current	5 mA (typical)

Control input

Number of inputs	2
Connection method	2, 3-conductor
Input voltage	24 V DC
	5 V DC
Maximum input voltage	8 V DC
Input current	5 mA (typical)

Outputs

Number of outputs	1
Connection method	2-wire (shielded)
Output voltage	24 V DC
Output current	500 mA

Inline potential routing

Communications power U_L	7.5 V DC
Current consumption from U_L	max. 50 mA
	Typ. 40 mA
Segment supply voltage U_S	24 V DC
Current consumption from U_S	max. 1 A

Certificates / Approvals



Certification ABS, CUL, DNV, GL, GOST, UL
 Certifications applied for: LR / BV

Accessories

Item	Designation	Description
Marking		
0809492	ESL 62X10	Insert strip for laser printer, lettering field: 62 x 10 mm
2727501	IB IL FIELD 2	Labeling field, width: 12.2 mm
Plug/Adapter		
2732664	IB IL AO/CNT-PLSET	Connector set
2726353	IB IL SCN-6 SHIELD	Inline shield connector
2726337	IB IL SCN-8	Connector, for digital 1, 2 or 8-channel Inline terminals

Diagrams/Drawings

Connection diagram

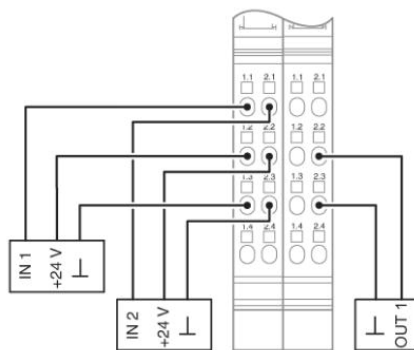

Block diagram

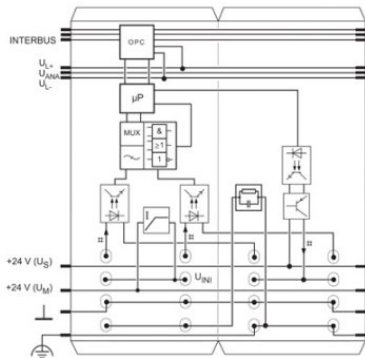

Dimensioned drawing

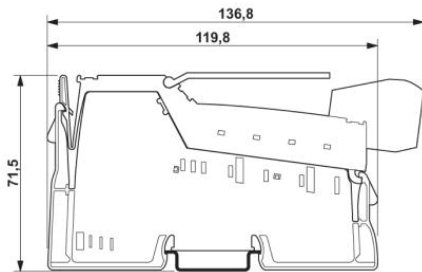

Address

PHOENIX CONTACT Inc., USA
586 Fulling Mill Road
Middletown, PA 17057, USA
Phone (800) 888-7388
Fax (717) 944-1625
<http://www.phoenixcon.com>



© 2011 Phoenix Contact
Technical modifications reserved;