

KYCON, Inc. 1810 Little Orchard Street, San Jose, CA 95125 (408)494-0330

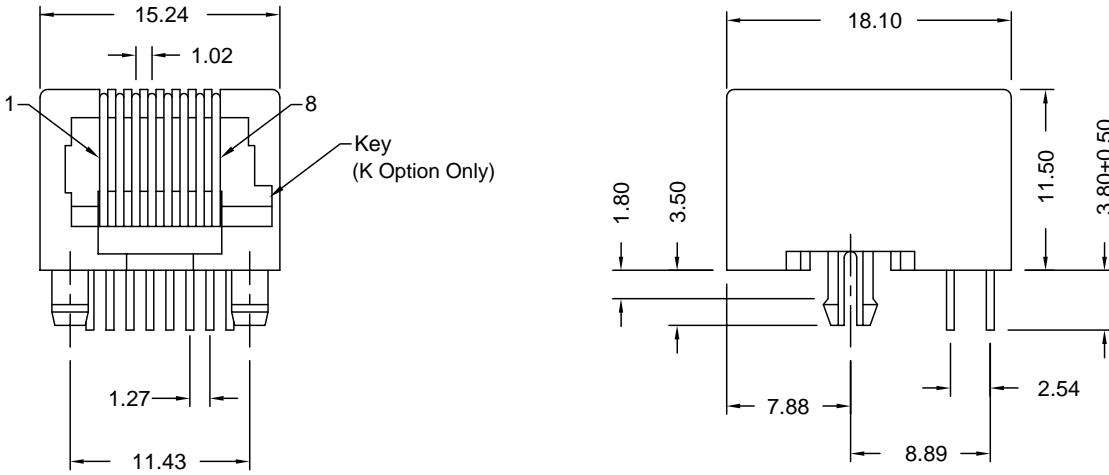

Materials and Finish

Housing Material-
PBT Thermoplastic
UL 94V-0 Rated
Color: Black

Design meets UL 1863 Sec. 8
Electrical Probe and Sec. 20
Child Finger test requirements

Contact Material-
Phosphor Bronze

Contact Plating Options-
Standard: 0.0001" Nickel
Plating, Selective Plating
0.00015" Gold on Contact
Area, Gold on Entire Contact

50 Option: 0.0001" Nickel Plating,
Selective Plating 0.000050"
Gold on Contact Area to
Comply with FCC Requirements
Under No. 47 C.F.R. Part 68,
Subpart F, Gold on Entire Contact

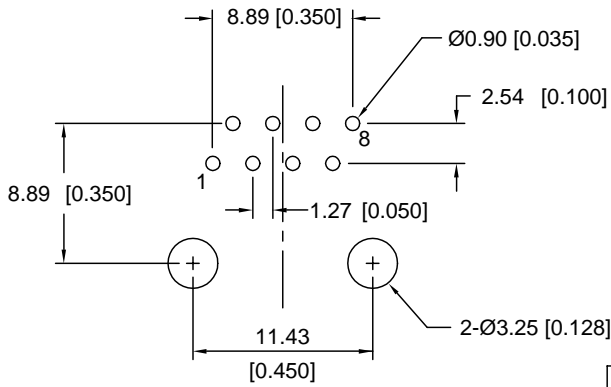

Recommended PCB Layout
(Top View)

Part Number	Contact Area Plating Finish
GM-N-88K	15u" Gold (standard)
GM-N-88K-50	50u" Gold (50 option)

CSA Certified File No. LR78160
UL Recognized File No. E134345

Tolerances
X.X ± 0.25
X.XX ± 0.15
Unless Stated
Otherwise

REVISION	DATE	DESCRIPTION	DRAWN BY	REV CHECK BY	UNITS
C	11/23/98	Rev PCB Layout	J. Kring	T. Gokcek	mm [in]
C1	4/24/01	ECD 01-056	REVISION BY	CHECK DATE	DATE
C2	3/28/03	ECD 03-011	C. Leiva	4/3/03	1/26/98

GM-N-88K

Right Angle Modular Jack
8 position, 8 contacts, Keyed

