

REV	DATE	DESCRIPTION	BY	CHK	APP
AA	22				
M		REDWN & REV; EC 0210-0111-95	5-11-95	GG	NJ

- 1. MATERIAL: HOUSING PBT POLYESTER, BLACK. TERMINAL-0.35 (.0138) THICK PHOS-BRONZE PLATED WITH 1.27µm (.000050) THICK HARD GOLD IN LOCALIZED GOLD PLATE AREA AND 2.03µm (.000080) THICK TIN LEAD IN SOLDER AREA OVER 1.27µm (.000050) THICK NICKEL UNDERPLATE.
- 2. CAVITY CONFORMS TO FCC RULES AND REGULATIONS PART 68 AND REA BULLETIN 345-81, FE-76 SPECIFICATION FOR MODULAR TELEPHONE HARDWARE.
- 3. ALL DIMENSIONS SHOWN ARE MAXIMUM UNLESS OTHERWISE SPECIFIED.

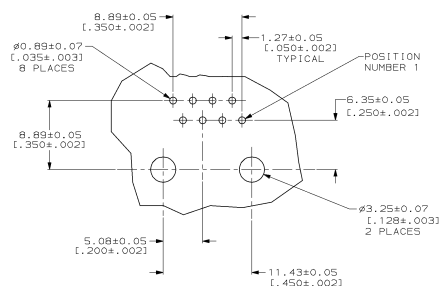
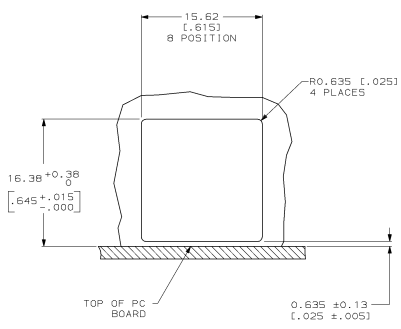
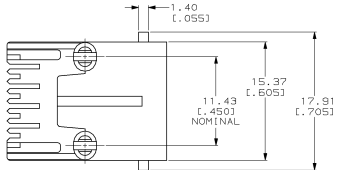
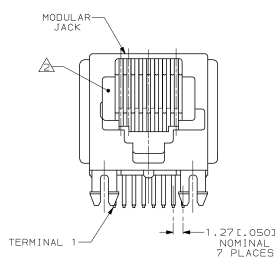
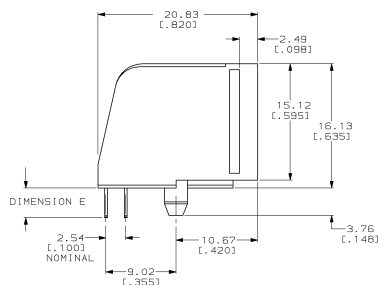

SUGGESTED PRINTED CIRCUIT BOARD LAYOUT
 NONCOMPONENT SIDE SHOWN

DIMENSION E	CONTACTS	PART NUMBER
3.20 (.126)	8	520252-5
4.32 (.170)	8	520252-4

AMP Incorporated Harrisburg, PA 17105-3608		DATE: 05-11-95 BY: JONES CHECKED: 5-23-95 APPROVED: 5-30-95	AMP
ORDER NO. BY: 1104481	ORDER NUMBER 108-1163	PART NUMBER 114-2048	DESCRIPTION MODULAR JACK ASSEMBLY, SIDE ENTRY, 8 POSITION, KEYED, FLANGELESS, WITH PANEL STOPS
MATERIAL PBT	FINISH GOLD	ORDER CODE -	DRAWING NO. A1100779
CUSTOMER DRAWING		PART NO. 520252	SCALE 4:1