

RJMG-64XX-XX-X1 SHOWN (WITHOUT SIDE TABS)

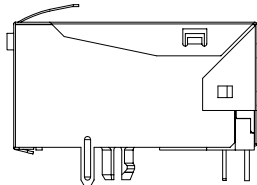

REVISIONS				
SYM	ZONE	ECN, ERN NO.	DATE	APPRD.
8		ADD MORE DIMENSIONS...ETC	01/04/19	D.M.M.
9		Add "U" Ratio, Chg "SD" to "P"	01/16/21	D.M.M.
10		Add Tolerances	02/13/28	L.C.
11		ADD SHIELD OPTION PICTURE	DEC.19/02	L.C.
12		ADD TOL ON CUTOUT & PANEL DEPTH & CONNECTOR WIDTH.	FEB.10/03	L.C.

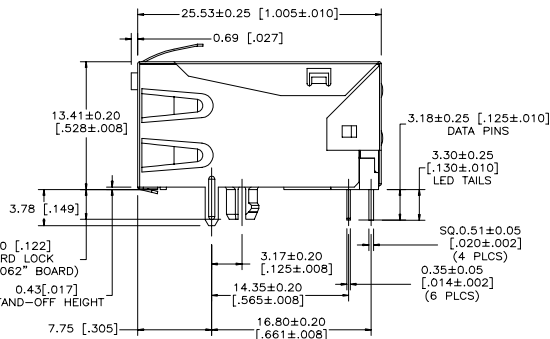
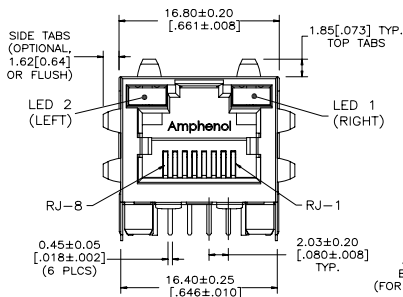
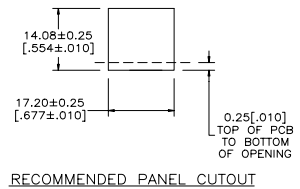

AMPHENOL PART NUMBER CONFIGURATION

RJMG-6XXX-XX-X1		TIA WIRING
3: STANDARD SHIELD, SIDE TABS	0: STANDARD	(Tx PAIR TO RJ1&2, Rx TO RJ3&6)
4: OPTIONAL SHIELD, NO SIDE TABS	A: CROSS-OVER	(Tx PAIR TO RJ3&6, Rx TO RJ1&2)
LED 1 DESIGNATION	TURNS RATIO (TRANSMIT)	
CODE	FORWARD	REVERSE
0	GREEN	YELLOW
1	YELLOW	GREEN
2	RED	ORANGE
3	GREEN	YELLOW
4	RED	GREEN
5	GREEN	ORANGE
6	GREEN	ORANGE
7	RED	YELLOW
LED 2 DESIGNATION	TERMINATION OPTIONS	
SEE LED 1	(SEE SHEET 2 AND 3 FOR SCHEMATIC)	
	3: 4x75 OHM RESISTORS, 68pF (2KV)	
	4: 2x0 OHM RESISTORS, 68pF (2KV)	
	5: 2x75 OHM RESISTORS, 68pF (2KV)	
	6: 3x75 OHM RESISTORS, 68pF (2KV)	
	7: 4x75 OHM RESISTORS, 1000pF (2KV), TRANSMIT SHUNT CHOKER.	
	8: 4x75 OHM RESISTORS, 1000pF (2KV), TRANSMIT SHUNT CHOKER.	
	9: 4x75 OHM RESISTORS, 1000pF (2KV), TRANSMIT SHUNT CHOKER.	
	SPECIAL PIN OUT FOR CHIP 82559.	
	A: 4x75 OHM RESISTORS, 1000pF (2KV) SPECIAL	
	B: 4x75 OHM RESISTORS, 1000pF (2KV) SPECIAL	

NOTE: TERMINATION OPTIONS "7", "9", "A" AND "B" ONLY AVAILABLE FOR 1:1 TURN RATIO.

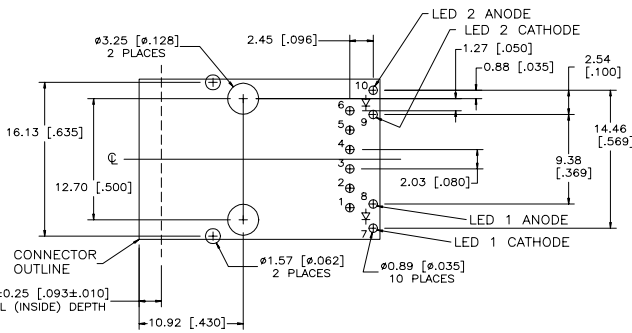

MATERIAL	DRAWN S.CHEN 1999/05/03	DATE 1999/05/03	Amphenol Canada Corp.
DESIGNED S.CHEN 1999/05/03	CHECKED R.JATOU 1999/11/12	I.E. APPRD. G.BANYARD 1999/11/12	
Q.A. APPRD. A.CANDY 1999/11/12	DWG. APPRD. D.M.M. 1999/11/12	ENG. REL. NO. ECN 99-A103	
REF. RJMG+ FAMILY	DIMENSIONS ARE IN [mm] [INCHES]	CODE ID. NO. 03554	
FINISH	DWG. C	DRAWING NO. P-RJMG-6XXX-XX-X1	REV. 12
	SCALE NTS	WT. -----	SURF. -----
			SHEET 1 OF 3

THIS DOCUMENT CONTAINS PROPRIETARY INFORMATION AND SUCH INFORMATION MAY NOT BE DISCLOSED TO OTHERS FOR ANY PURPOSE OR USED FOR MANUFACTURING PURPOSES WITHOUT WRITTEN PERMISSION FROM AMPHENOL CANADA CORP.

REVISIONS				
SYM	ZONE	ECN, ERN NO.	DATE	APPRD.
8		ADD MORE DIMENSIONS...ETC	01/04/19	D.M.M.
9		Add "U" ratio, chg "SD" to "P"	01/06/21	D.M.M.
10		ADD TOLERANCE	02/03/28	L.C.
11		ADD SHIELD OPTION PICTURES.	DEC.19/02	L.C.
12		ADD TOL ON CUTOUT, PANEL DEPTH CONNECTOR WIDTH.	FEB.10/03	L.C.

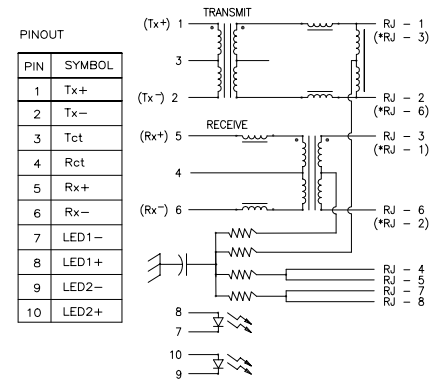
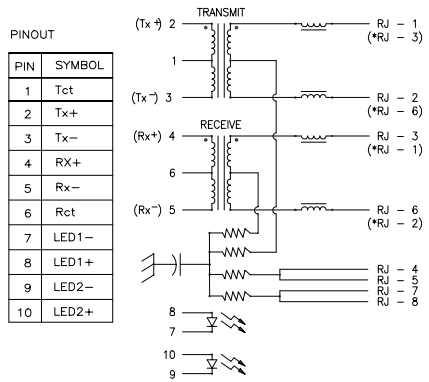
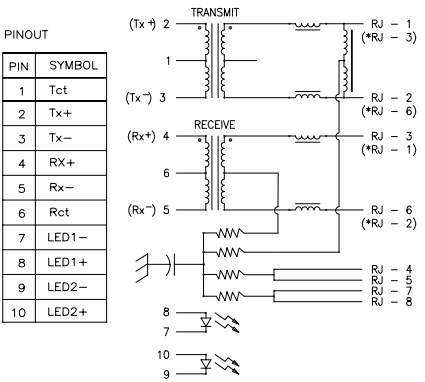
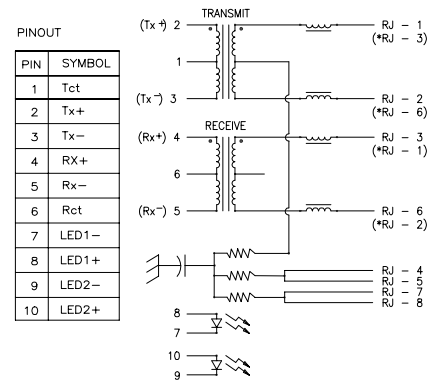
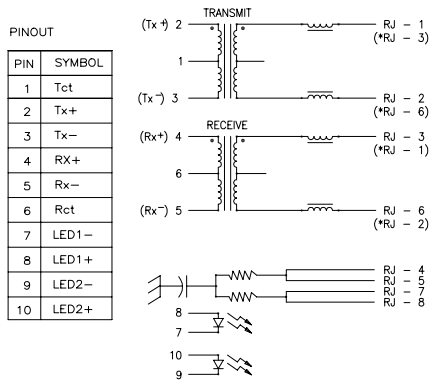
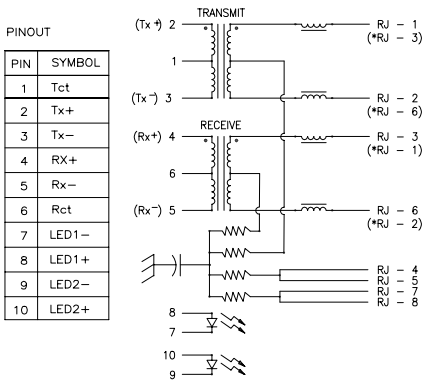

- NOTE
- DESIGNATORS 1 TO 10 ARE PRINTED WIRE BOARD CONNECTIONS.
  - DIFFERENT CAPACITOR VALUES ARE AVAILABLE UPON REQUEST.
  - NUMBERS WITH MARK "\*" SHOW THE CONNECTION FOR RJMG-6XXX-XX-A1.

MATERIAL	DRAWN	S.CHEN	DATE	1999/05/03	Amphenol Canada Corp.		
	DESIGNED	S.CHEN	DATE	1999/05/03			
FINISH	CHECKED	R.JATOU	DATE	1999/11/12	TITLE		
	I.E. APPRD.	G.BANYARD	DATE	1999/11/12		SINGLE PORT RJmag CONNECTOR, SHIELD, WITH R&C TERMINATION	
DIMENSIONS ARE IN CODE ID. NO.	Q.A. APPRD.	A.CANDY	DATE	1999/11/12	DWG		
	ENG. REL. NO.	ECN 99-A103	SCALE	NTS		DRAWING NO.	
	REF.	RJMG+ FAMILY	WT.	-----			P-RJMG-6XXX-XX-X1
	mm	03554	SURF.	-----			
				12			
					SHEET 2 OF 3		

THIS DOCUMENT CONTAINS PROPRIETARY INFORMATION AND SUCH INFORMATION MAY NOT BE DISCLOSED TO OTHERS FOR ANY PURPOSE OR USED FOR MANUFACTURING PURPOSES WITHOUT WRITTEN PERMISSION FROM AMPHENOL CANADA CORP.

PIN	SYMBOL
1	Tx+
2	Tx-
3	Tct
4	Rx+
5	Rx-
6	Rct
7	LED1-
8	LED1+
9	LED2-
10	LED2+

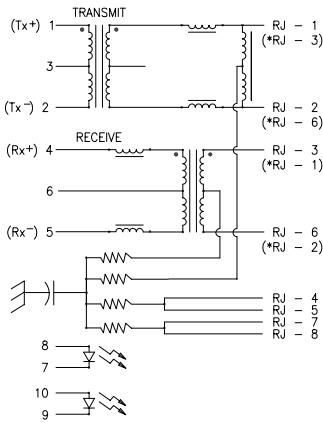

PIN	SYMBOL
1	Tct
2	Tx+
3	Tx-
4	Rx+
5	Rx-
6	Rct
7	LED1-
8	LED1+
9	LED2-
10	LED2+

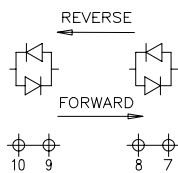
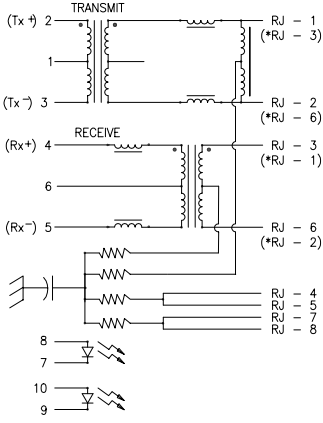

REVISIONS				
SYM	ZONE	ECN, ERN NO.	DATE	APPRD.
8		ADD MORE DIMENSIONS...ETC	01/04/19	D.M.M.
9		Add "U" ratio, chg "SD" to "P"	01/06/21	D.M.M.
10		ADD TOLERANCES	02/03/28	L.C.
11		ADD SHIELD OPTION PICTURES.	DEC.19/02	L.C.
12		ADD TOL ON CUTOUT & PANEL DEPTH & CONNECTOR WIDTH.	FEB.10/03	L.C.

**ELECTRICAL SPECIFICATION (@25°C), TURN RATIO: 1:1, 1.25:1,  $\sqrt{2}$ :1 AND 2:1**

INSERTION LOSS	0.8dB TYP.	1.0dB MAX.	1-100MHz
RETURN LOSS	-22dB TYP.	-18dB MIN.	1-30MHz
	-18dB TYP.	-16dB MIN.	30-60MHz
	-12dB TYP.	-10dB MIN.	60-100MHz
OCL	500uH TYP.	400uH MIN.	100KHz
		.8mA DC BIAS	
DC RESISTANCE	0.5ohm TYP.	1.0ohm MIN.	DC
CM TO CM REJECTION	40dB TYP.	38dB MIN.	0-100MHz
CM TO DM REJECTION	40dB TYP.	35dB MIN.	0-100MHz
HIPOUT (ISOLATION)	2KVrms	1.5KVrms	DC
CROSSTALK (PAIR TO PAIR)	-38dB TYP.	-35dB MIN.	0-100MHz
(LED TO Tx/Rx)	-60dB TYP.	-50dB MIN.	0-100MHz
COMMON MODE IMPEDANCE	3.5Kohm TYP.	3Kohm MIN.	0-10MHz
	575ohm TYP.	550ohm MIN.	10-100MHz

**ELECTRICAL SPECIFICATION (@25°C), TURN RATIO: 1: $\sqrt{2}$ , 1:2 AND 1:2.5**

INSERTION LOSS	0.8dB TYP.	1.0dB MAX.	1-10MHz
RETURN LOSS	-20dB TYP.	-16dB MIN.	1-10MHz
OCL RECEIVE	500uH TYP.	400uH MIN.	100KHz
		.8mA DC BIAS	
OCL TRANSMIT	35uH TYP.	28uH MIN.	100KHz
		.8mA DC BIAS	
DC RESISTANCE	0.5ohm TYP.	1.0ohm MIN.	DC
CM TO CM REJECTION	40dB TYP.	38dB MIN.	0-100MHz
CM TO DM REJECTION	40dB TYP.	35dB MIN.	0-100MHz
HIPOUT (ISOLATION)	2KVrms	1.5KVrms	DC
CROSSTALK (PAIR TO PAIR)	-38dB TYP.	-35dB MIN.	0-100MHz
(LED TO Tx/Rx)	-60dB TYP.	-50dB MIN.	0-100MHz
COMMON MODE IMPEDANCE	3.5Kohm TYP.	3Kohm MIN.	0-10MHz
	575ohm TYP.	550ohm MIN.	10-100MHz

**MATERIALS:**

PLASTIC HOUSING: THERMOPLASTIC POLYESTER  
FLAMMABILITY RATING UL 94V-0

CONTACTS: PHOSPHOR BRONZE  
PLATING: 50 MICROINCHES [1.27 MICRONS] MIN.  
NICKEL OVERALL  
30 MICROINCHES [1.27 MICRONS] MIN.  
GOLD ON MATING SURFACES  
100 MICROINCHES [2.54 MICRONS] MIN.  
TIN/LEAD ON CONTACT TAILS

SHIELD: COPPER ALLOY  
PLATING: TIN-LEAD ALLOY

MATERIAL	DRAWN S.CHEN 1999/05/03 DESIGNED S.CHEN 1999/05/03 CHECKED L.KWAPISZ 1999/11/12 I.E. APPRD. G.BANYARD 1999/11/12 Q.A. APPRD. A.CANDY 1999/11/12	DATE	Amphenol Canada Corp.
FINISH	DWG. APPRD. D.M.M. 1999/11/12 ENG. REL. NO. ECN 99-A103 REF. RJMG+ FAMILY DIMENSIONS ARE IN CODE ID. NO. 03554	SCALE NTS	
TITLE			SINGLE PORT RJmag CONNECTOR, SHIELD, WITH R&C TERMINATION
DRAWING NO.			P-RJMG-6XXX-XX-X1
REV.			12
SHEET			3 OF 3

THIS DOCUMENT CONTAINS PROPRIETARY INFORMATION AND SUCH INFORMATION MAY NOT BE DISCLOSED TO OTHERS FOR ANY PURPOSE OR USED FOR MANUFACTURING PURPOSES WITHOUT WRITTEN PERMISSION FROM AMPHENOL CANADA CORP.