

# Semi-Rigid and RG Coax Cables - Straight

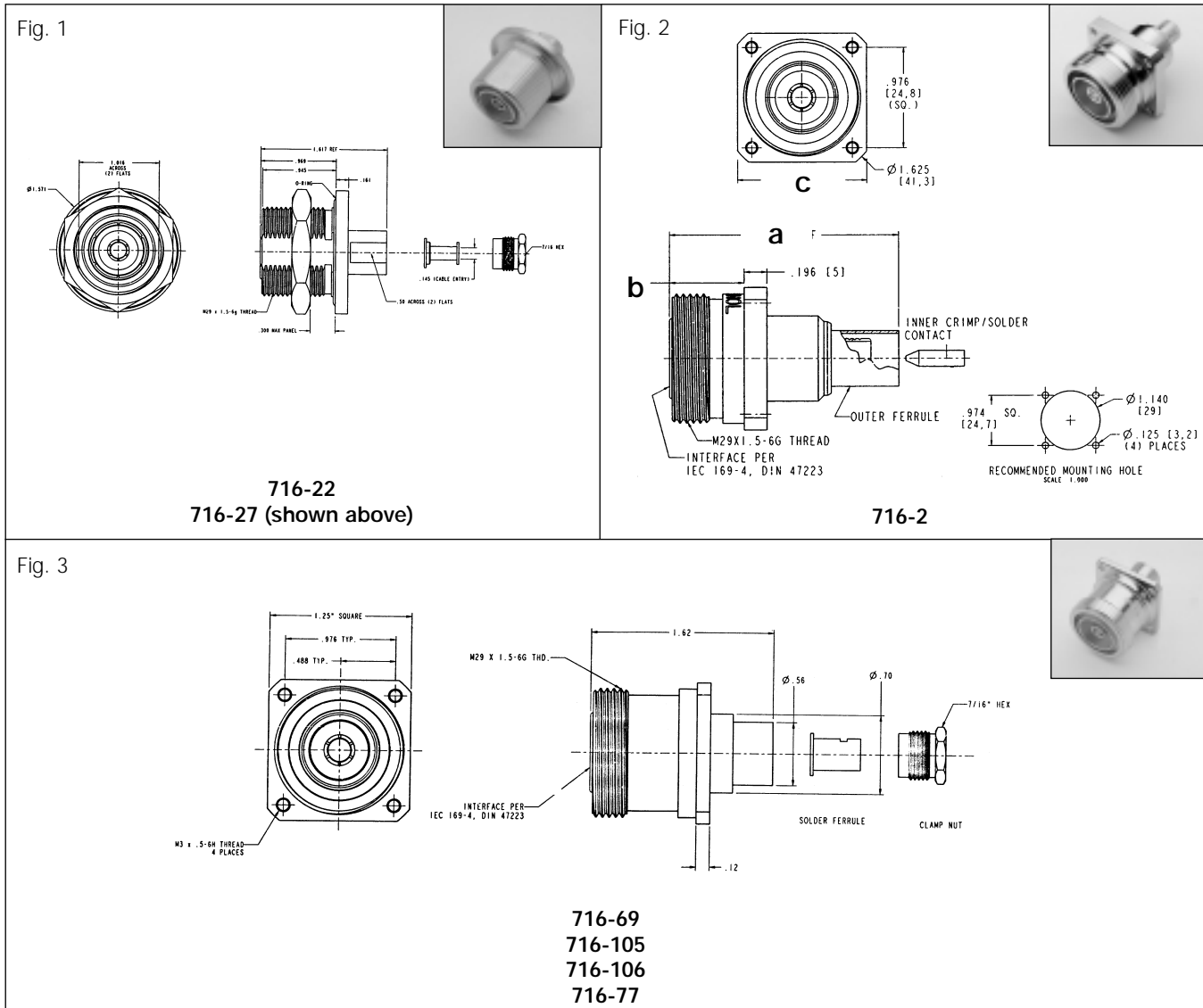

## 7/16 BULKHEAD JACKS -Straight (Solder)

Cable	Inner Attachment	a	b	c	Body	Contact	Amphenol Number	FIG.
.141 Semi-Rigid	Solder	1.617	.969	1.016	W Bronze	Silver	716-27	1
.250 Semi-Rigid	Solder	1.617	.969	1.016	Silver	Silver	716-22	1

## 7/16 PANEL JACKS - Straight (Solder)

Cable	Inner Attachment	a	b	c	Body	Contact	Amphenol Number	FIG.
.250 Semi-Rigid	Solder	1.889	.804	1.250	W Bronze	Silver	716-77	3
.250 Semi-Rigid	Solder	1.62	—	1.250	Silver	Silver	716-69	3
.250 Semi-Rigid	Solder	.753	1.043	1.250	W Bronze	Silver	716-105	3
.141 Semi-Rigid	Solder	.753	1.043	1.250	W Bronze	Silver	716-106	3

## 7/16 PANEL JACKS - Straight (Crimp)

Cable	Inner Attachment	a	b	c	Body	Contact	Amphenol Number	FIG.
RG393	Crimp	1.988	.649	1.250	W Bronze	Silver	716-2	2