

NOTES:

- MATERIALS OF CONSTRUCTION:
SHELL, BODY & FERRULE = BRASS, NICKEL PLATED
OUTER CONTACT = PHOSPHOR BRONZE, GOLD PLATED
CONTACT PIN = BRASS, GOLD PLATED
INSULATOR = TEFLON PER MIL-P-19468
- CRIMPED FERRULE = HEX CRIMP SIZE .255
CRIMPED CONTACT PIN = SQUARE CRIMP SIZE .043

156-112-R659		REVISIONS			
DRAWING NO.	REV	DESCRIPTION	DATE	ECO	APPR
THIRD ANGLE PROJ.	A	RELEASE TO MFG.	5/17/00	43373	CPM

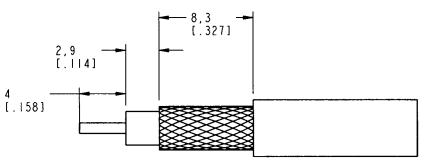
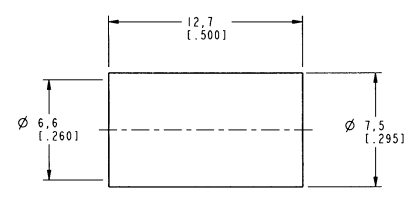
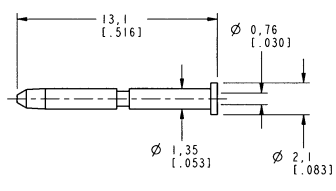
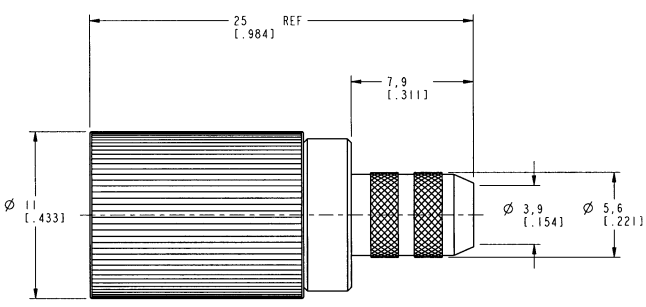
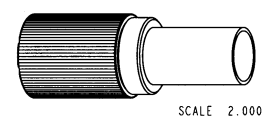

RECOMMENDED CABLE STRIPPING DIMENSIONS
SCALE 3.000

CUSTOMER OUTLINE DRAWING
FOR REFERENCE ONLY

UNLESS OTHERWISE SPECIFIED, DIMENSIONS ARE IN INCHES AND TOLERANCES ARE: 0.5 - 6mm ±0.2mm 6 - 30mm ±0.4mm 30 - 120mm ±0.6mm	MATERIAL	DRAWN C. McGRATH	DATE 11-May-00	TITLE	Amphenol Amphenol Corporation Communication and Network Products Division Danbury, CT U.S.A. 06810 SCALE: 4.0:1 SHEET 2 OF 2
	REFERENCE EAR 967564-0 GEN 156-112-R659	ENGINEER T. AUBIN	DATE 11-May-00	1.6/5.6 CRIMP PLUG	
NOTICE - These drawings, specifications, or other data (1) are, and remain the property of Amphenol Corp. (2) must be returned upon request; and (3) are confidential and not to be disclosed to any person other than those to whom they are given by Amphenol Corp. The furnishing of these drawings, specifications, or other data by Amphenol Corp., or to any other person to anyone for any purpose is not to be regarded by implication or otherwise in any manner licensing, granting rights or permitting such holder or any other person to manufacture, use or sell any product, process or design, patented or otherwise, that may in any way be related to or disclosed by said drawings, specifications, or other data.	APPROVED 	DATE 5/12/00	CAD FILE I:\1656\156-112-R659	CODE ID 74868	DWG SIZE B
				DRAWING NO. 156-112-R659	REV A