

REV.	DATE	DESCRIPTION
NC	10/30/05	INITIAL RELEASE

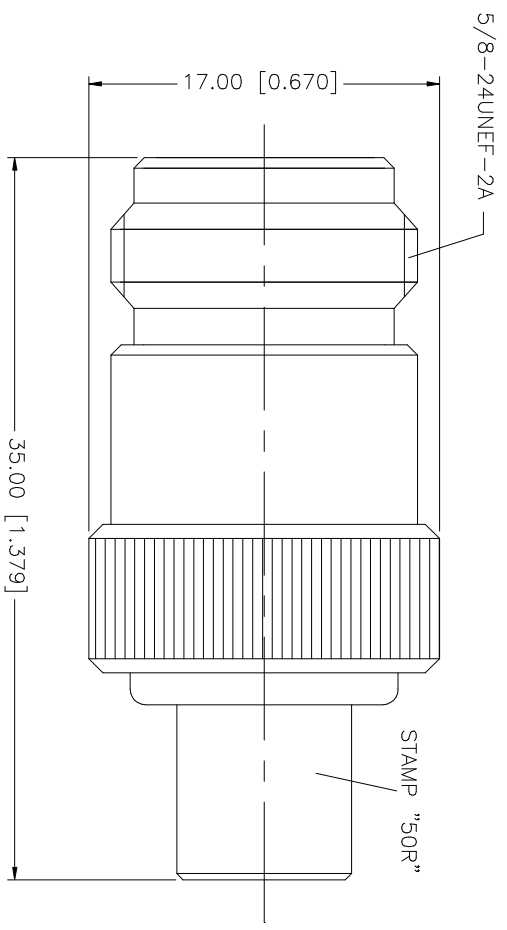

NOTE:
RESISTOR TOLERANCE
1 WATT 1% - 50ohm

QTY	FINISH	MATERIAL	DESCRIPTION
1	NICKEL	BRASS	RIVET
1	NICKEL	BRASS	CHAIN
1	GOLD	PHOS. BRONZE	CONTACT PIN
1	NATURAL	TEFLON	INSULATOR
1	NECOCOTE	BRASS	SHELL/BODY
			DESCRIPTION

UNLESS OTHERWISE SPECIFIED DIMENSIONS ARE IN INCHES AND FOR CUSTOMER REFERENCE ONLY.	
UNLESS OTHERWISE SPECIFIED TOLERANCES FOR MILLIMETERS ARE:	
0.3 - 8mm	± 0.20mm
8 - 30mm	± 0.40mm
30 - 120mm	± 0.50mm
UNLESS OTHERWISE SPECIFIED TOLERANCES FOR INCHES ARE:	
.020 - .315	± 0.007"
.315 - 1.180	± 0.015"
1.180 - 4.724	± 0.020"
DO NOT SCALE DRAWING	

APPROVALS	DATE
DRAWN G.R.S.	10/30/05
CHECKED	
ISSUED	

CAD FILE	C:/202/202110-.DWG
DWG. NO.	202110.DWG
REV.	NC
SIZE	A
SCALE	NA

PART DESCRIPTION	
N TERMINATOR JACK	
PART NO.	202110