

FACE AREA 5.429 SQ INCHES
 NOT SCALE THIS DRAWING.
 REMOVE ALL BURRS, BREAK SHARP EDGES AND CORNERS
 TO MAXIMUM, UNLESS OTHERWISE SPECIFIED.
 UNLESS OTHERWISE SPECIFIED, ALL DIMENSIONS ARE AFTER PLATING.

O.S.

83-132		REVISIONS			
DRAWING NO.	REV	DESCRIPTION	DATE	ECO	APPR
THIRD ANGLE PROJ.		OFFICIAL ENG. RELEASE TO MFG.			
	AZ	REDRAWN WAS 'C' SIZE; DEL NOTES 2 & 3 ALSO FINISH COL; ADD NOTES 4 THRU 6; ADD DASH 16	11/16/94	4-0309	CPM/D/R

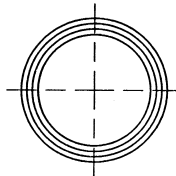
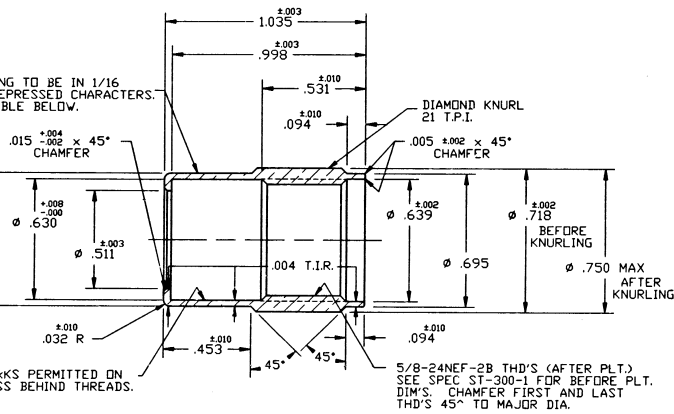

PART No.	STAMPING	PART No.	STAMPING
83-132-1	NONE	83-132-8	AMPHENOL 83-822 2 SPACES MIN
83-132-2	AMPHENOL 83-1SP-1050 2 SPACES MIN 74868 PL-259 49190 2 SPACES MIN 2 SPACES MIN	83-132-9	AMPHENOL 83-822-1003 1 SPACE
83-132-3	PL259 QL228 2 SPACES MIN	83-132-10	AMPHENOL 83-886 1 SPACE
83-132-4	PL259 49190 2 SPACES MIN	83-132-11	AMPHENOL 83-102 1 SPACE
83-132-5	20983-PL-259	83-132-12	NONE
83-132-6	AMPHENOL 83-1SP-H 2 SPACES MIN 74868 PL-259 49190 2 SPACES MIN 2 SPACES MIN	83-132-13	AMPHENOL 83-1SP 2 SPACES MIN 74868 PL-259 49190 2 SPACES MIN 2 SPACES MIN
83-132-7	AMPHENOL 83-1SP-1007 1 SPACE	83-132-14	K40 ELECTRONICS 2 SPACES MIN
		83-132-15	AMPHENOL
		83-132-16	AMPHENOL PL-259

UNLESS OTHERWISE SPECIFIED, DIMENSIONS ARE IN INCHES AND TOLERANCES ARE:
 DECIMAL 3 PLACE DECIMAL ANGLES
 (1 mm) ± .005 (0.127 mm) ± 1°

Drawings, specifications or other data (1) are, and remain the property of Amphenol Corp. (2) must be returned upon request; and (3) are not to be disclosed to any person other than those to whom they are furnished. The furnishing of these drawings, specifications, or other data by Amphenol Corp., or to any other person for any purpose is hereby implied or otherwise in any manner licensing, granting or otherwise in any manner, that may in any way be related to the drawings, specifications, or other data.

MATERIAL
 BRASS
 QQ-B-626
 QCOMP. 22, 1/2H

REFERENCE
 SC-D-5940-D

DRAWN
 T. ALBERA
 DATE
 1/17/89

ENGINEER
 D. ROYCE
 DATE
 1/31/89

APPROVED
 D. ROYCE
 DATE
 1/31/89

CAD FILE
 H:\DEPT611\HARD\CNUT\083\132

TITLE
 COUPLING
 NUT

CODE ID
 74868

DWG SIZE
 B

DRAWING NO.
 83-132

Amphenol
 Amphenol Corporation
 RF/Microwave Operations
 Danbury, Conn. U.S.A. 06810

SCALE: 2:1 SHEET OF
 ISSUE
 AZ