

REV.	DATE	DESCRIPTION
A	01/07/01	ADD CRIMP NOTES/ MODIFY CONTACT PIN, FERRULE

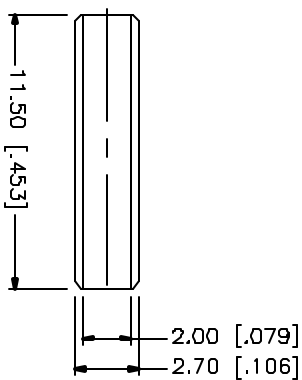

- CRIMP NOTES:
1. CRIMPED FERRULE
HEX CRIMP SIZE .178"
 2. CRIMPED CONTACT PIN
HEX CRIMP SIZE .043"

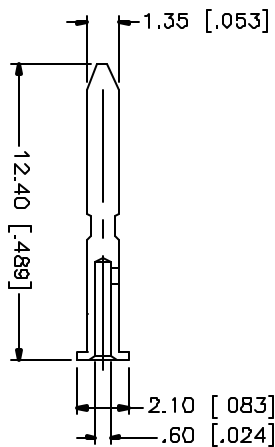
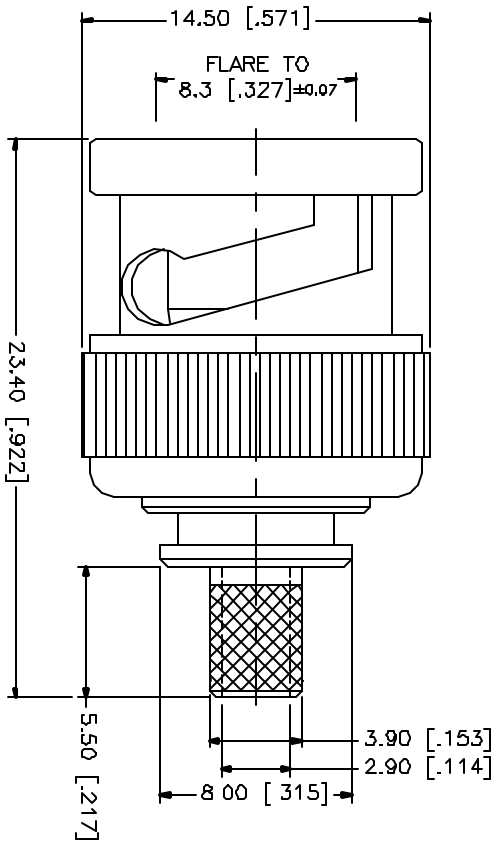
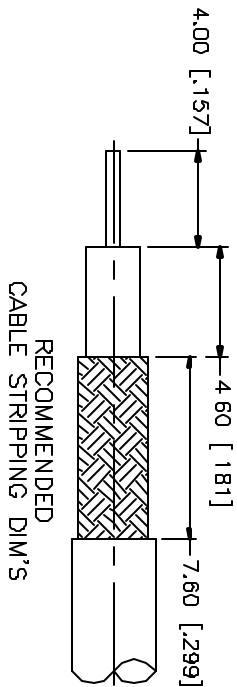
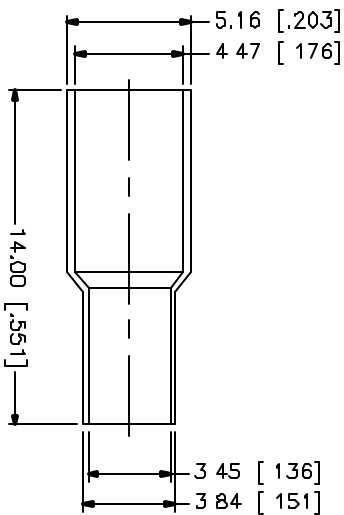

DESCRIPTION	MATERIAL	FINISH	UNLESS OTHERWISE SPECIFIED DIMENSIONS ARE IN MILLIMETERS DIMENSIONS IN () ARE IN INCHES FOR CUSTOMER REFERENCE ONLY	APPROVALS	DATE	TITLE	SCALE	NA	PART NO.	112491-11	SHEET	1 OF 1		
1 SHELL	BRASS	NICKEL	UNLESS OTHERWISE SPECIFIED TOLERANCES FOR MILLIMETERS ARE: 0.5-6 = ± 0.2 6-30 = ± 0.4 30-120 = ± 0.6 120-315 = ± 1 315-1000 = ± 1.6 1000-2000 = ± 2.4	DRAWN	01/07/01	Comnex Connector Corporation BNC CRIMP PLUG (FOR LIBERTY RGB6C/22-2P CABLE)	A	NA	99001	112491-11.DWG				
2 BODY	BRASS	NICKEL		CHECKED										
3 INSULATOR	TEFLON	NATURAL		ISSUED										
4 CONTACT PIN	BRASS	GOLD												
5 SLEEVE	TEFLON	NATURAL												
6 FERRULE	BRASS	NICKEL												
7														
8				DO NOT SCALE DRAWING										