

SALES

10-Sep-2002 18:25

REVISIONS		
ISS	ZONE	DESCRIPTION/PER REQUEST/DATE

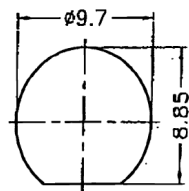

RECOMMENDED MOUNTING HOLE (建議安裝孔)

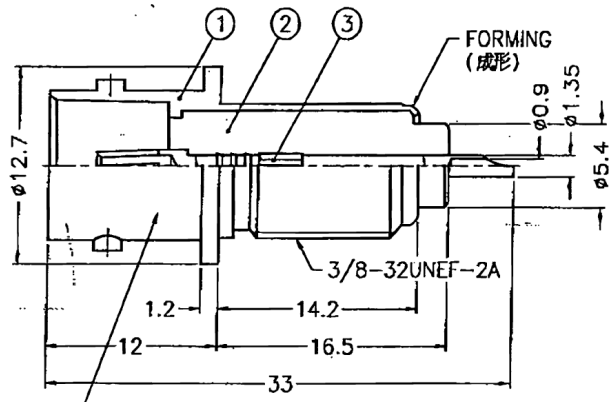

STAMP (IF ANY)
噴字 (若有要求)

- NOTES: FINISH (PLATING THICKNESS IN MICRO-INCHES)
- BRASS PER QQ-B-626
 - BRASS PER QQ-B-613
 - NICKEL PL. 100 MIN. THICK OVER COPPER STRIKE
 - GOLD PL. 3 MIN. THICK OVER NICKEL PL. 100 MIN. THICK OVER COPPER STRIKE
 - PHOSPHOR BRONZE PER QQ-B-750
 - TEFLON MIL-P-19468

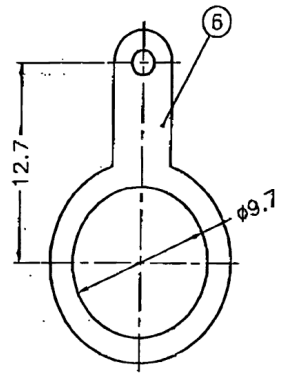
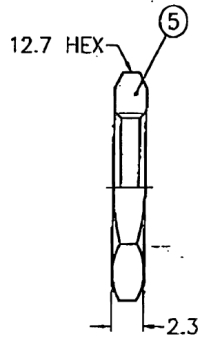
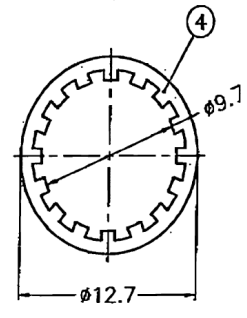

1. MAX. PANEL THICKNESS=9mm

NO.	DESCRIPTION	MATERIAL	FINISH	Q'TY	DRAWING NO.
6	SOLDER TAG	NOTE 2	NOTE 3	1	B7310-7
5	HEX NUT	NOTE 1	NOTE 3	1	HN127-3/8-32 X23
4	LOCK WASHER	NOTE 2	NOTE 3	1	LW-127/97X05
3	CONTACT PIN	NOTE 5	NOTE 4	1	B7312-3-75
2	INSULATOR	NOTE 6	NATURAL	1	B7312-2T-75
1	BODY	NOTE 1	NOTE 3	1	B7312-1

DIMENSIONS ARE IN MILLIMETERS
UNLESS OTHERWISE SPECIFIED
TOLERANCES
0.5-6 = ±0.2
6-30 = ±0.4
30-120 = ±0.6
120-315 = ±1
315-1000 = ±1.6
1000-2000 = ±2.4

PART NO.	112429
APPROVED	<i>Mark C</i> DATE 03-14-02
CHECKED	<i>Karl J</i> DATE 03-14-02
DRAWN	<i>Karl J</i> DATE 03-14-02
FILE NO.	F:\DWG\B\6351B3\75\MT3G

AMPHENOL CONNEX

TITLE	BNC BULKHEAD RECEPT. JACK
DRAWING NO.	KJ-B6351B3-NT3G-75
ITEM NO.	016351AAL01NA7F

70-DR 1/005 8