

REV.	DATE	DESCRIPTION
NC	06/30/05	INITIAL RELEASE
A	10/02/06	REMOVAL OF CRIMP NOTE 2

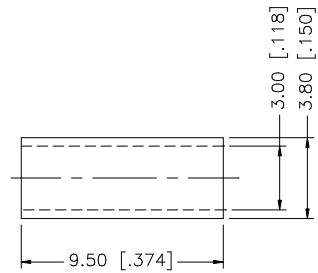
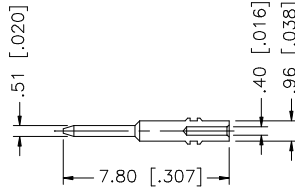
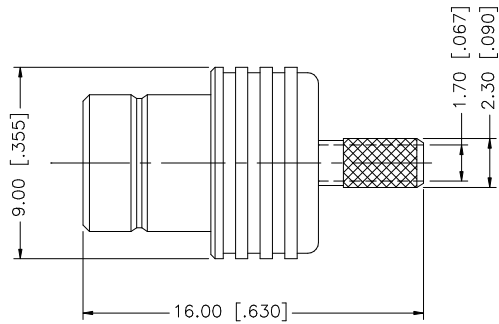
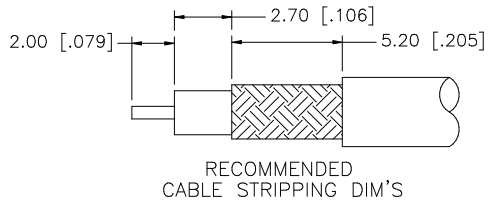

NOTE:
1. CRIMPED FERRULE
HEX CRIMP SIZE .128"

DESCRIPTION	MATERIAL	FINISH	QTY	UNLESS OTHERWISE SPECIFIED DIMENSIONS ARE IN MILLIMETERS. DIMENSIONS IN [] ARE IN INCHES AND FOR CUSTOMER REFERENCE ONLY.	APPROVALS	DATE	Amphenol Connex					
8				UNLESS OTHERWISE SPECIFIED TOLERANCES FOR MILLIMETERS ARE: 0.5 - 8mm ± 0.20mm 8 - 30mm ± 0.40mm 30 - 120mm ± 0.50mm UNLESS OTHERWISE SPECIFIED TOLERANCES FOR INCHES ARE: .020 - .315 = ± 0.007" .315 - 1.180 = ± 0.015" 1.180 - 4.724 = ± 0.020"	DRAWN	G.R.S.	10/02/06	PART DESCRIPTION SMZ CRIMP JACK (FOR RG-1279/U, 187A/U)				
7					CHECKED							
6						ISSUED			PART NO. 142107			
5						SHEET	1 OF 1					
4	FERRULE	COPPER	GOLD		1	CAD FILE		C:/142/142107.DWG	DWG. NO.	142107.DWG	REV. A	SIZE A
3	CONTACT PIN	BRASS	GOLD	1								
2	INSULATOR	TEFLON	NATURAL	1								
1	BODY	BRASS	GOLD	1								
DO NOT SCALE DRAWING												