

REV.	DATE	DESCRIPTION
NC	07/31/05	INITIAL RELEASE
A	11/02/05	ADD 141/U CABLE TO DESCRIPTION

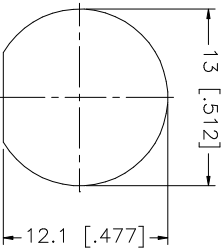

CRIMP NOTES:

1. CRIMPED FERRULE  
HEX CRIMP SIZE .320"
2. CRIMPED CONTACT PIN  
HEX CRIMP SIZE .068"
3. MAX. PANEL THICKNESS = 3.5mm

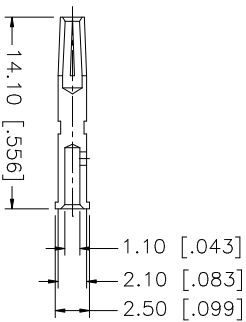
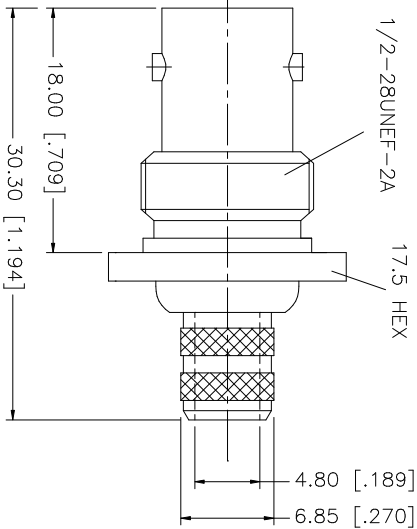
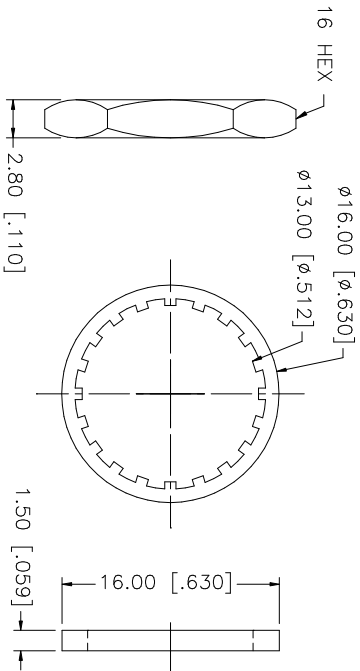
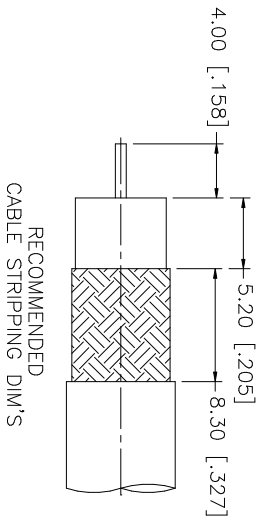
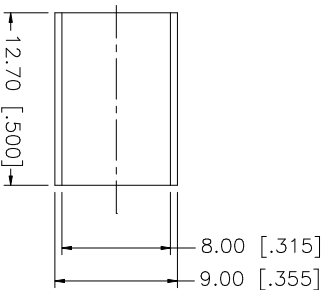

QTY	FINISH	MATERIAL	DESCRIPTION
1	NICKEL	COPPER	FERRULE
1	NICKEL	BRASS	HEX NUT
1	NICKEL	BRASS	LOCK WASHER
1	RED	RUBBER	GASKET
1	GOLD	PHOS. BRONZE	CONTACT PIN
1	NATURAL	TEFLON	INSULATOR
1	NICKEL	BRASS	BODY
			DESCRIPTION

APPROVALS	DATE
DRAWN G.R.S.	01/18/06
CHECKED	
ISSUED	
SHEET 1 OF 1	

CAD FILE	DWG. NO.	REV.	SIZE	SCALE
C:/112/112732.DWG	112732.DWG	A	A	NA

UNLESS OTHERWISE SPECIFIED DIMENSIONS ARE IN MILLIMETERS. DIMENSIONS IN [ ] ARE IN INCHES AND FOR CUSTOMER REFERENCE ONLY.
UNLESS OTHERWISE SPECIFIED TOLERANCES FOR MILLIMETERS ARE: 0.5 - 8mm ± 0.20mm 8 - 30mm ± 0.40mm 30 - 120mm ± 0.50mm
UNLESS OTHERWISE SPECIFIED TOLERANCES FOR INCHES ARE: .020 - .315 = ± 0.007" .315 - 1.180 = ± 0.015" 1.180 - 4.724 = ± 0.020"

**Amphenol Connex**

BNC BULKHEAD CRIMP JACK  
(FOR RG-6/U - 75ohm CABLE)

112732