

REV.	DATE	DESCRIPTION
NC	06/25/98	INITIAL RELEASE
A	07/20/05	UPDATE DRAWING FORMAT

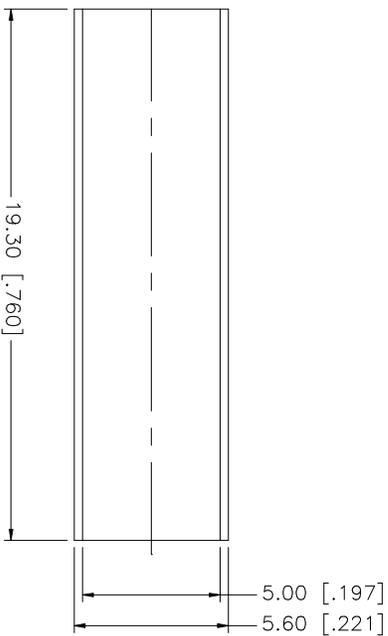
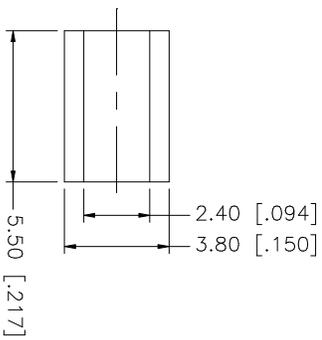
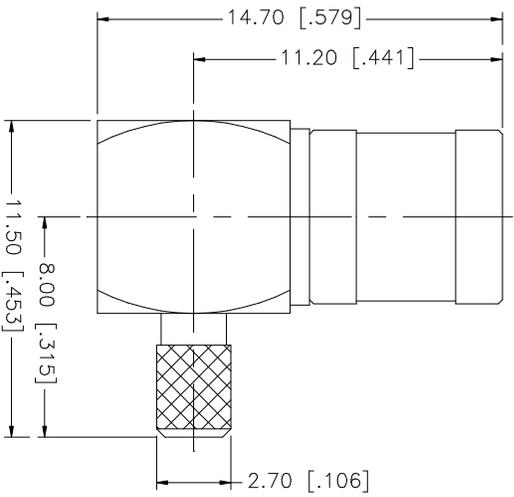
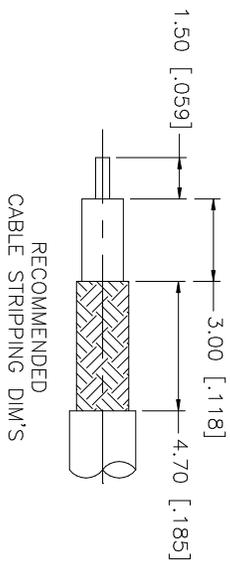

8	DESCRIPTION	MATERIAL	FINISH	QTY	UNLESS OTHERWISE SPECIFIED DIMENSIONS ARE IN INCHES AND FOR CUSTOMER REFERENCE ONLY.	APPROVALS	DATE	PART DESCRIPTION
7					UNLESS OTHERWISE SPECIFIED DIMENSIONS ARE IN INCHES AND FOR CUSTOMER REFERENCE ONLY.	DRAWN	07/20/05	Amphenol Connex SMB R/A CRIMP PLUG (FOR RG-178/U, 196/U CABLE)
6					TOLERANCES FOR MILLIMETERS ARE:	G.R.S.		
5	HEAT SHRINK TUBE			1	0.5 - 8mm ± 0.20mm	CHECKED		
4	FERRULE	BRASS	GOLD	1	8 - 30mm ± 0.40mm	ISSUED		
3	CONTACT PIN	BER. COPPER	GOLD	1	30 - 120mm ± 0.50mm	SHEET	1 OF 1	
2	INSULATOR	TEFLON	NATURAL	1	UNLESS OTHERWISE SPECIFIED DIMENSIONS FOR INCHES ARE:	CAD FILE		PART NO.
1	BODY	BRASS	GOLD	1	.020 - .315 = ± 0.007" .315 - 1.180 = ± 0.015" 1.180 - 4.724 = ± 0.020"	C:/142/142195.DWG		DWG. NO.
	DESCRIPTION	MATERIAL	FINISH	QTY	DO NOT SCALE DRAWING	C:/142/142195.DWG		DWG. NO.
						REV.	SCALE	
						A	NA	