

REV.	DATE	DESCRIPTION
NC	06/11/02	INITIAL RELEASE

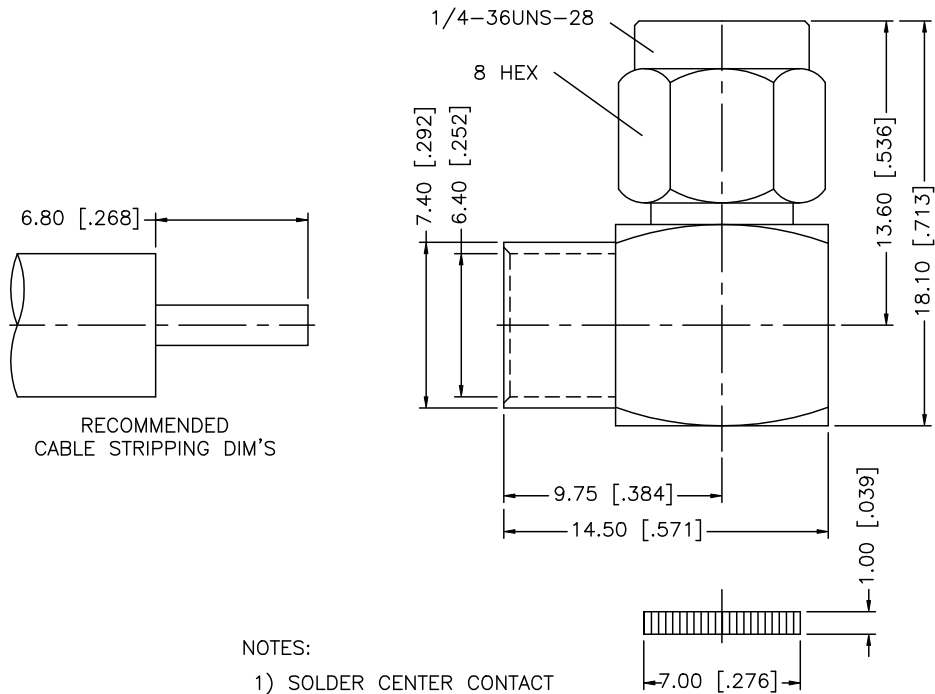

NOTES:  
1) SOLDER CENTER CONTACT

8				UNLESS OTHERWISE SPECIFIED DIMENSIONS ARE IN MILLIMETERS	APPROVALS	DATE	<h1 style="text-align: center;">Amphenol - Connex</h1> <p style="text-align: center;">CONNECTOR CORPORATION</p>			
7					DRAWN	G.R.S.				06/11/02
6				DIMENSIONS IN [ ] ARE IN INCHES FOR CUSTOMER REFERENCE ONLY	CHECKED		TITLE SMA R/A DIRECT SOLDER PLUG (FOR .250" SEMI RIGID CABLE)			
5					ISSUED					
4	COVER	BRASS	GOLD	UNLESS OTHERWISE SPECIFIED TOLERANCES FOR INCHES ARE: .XXX = ± 0.005" .XX = ± 0.010" .X = ± 0.020"			SIZE	FSCM NO.	DWG. NO.	REV.
3	CONTACT PIN	BRASS	GOLD		A	99001	132344.DWG	NC		
2	INSULATOR	TEFLON	NATURAL							
1	HOUSING/BODY	BRASS	GOLD							
	DESCRIPTION	MATERIAL	FINISH	DO NOT SCALE DRAWING			SCALE	PART NO.		SHEET
							NA	132344		1 OF 1