

REV.	DATE	DESCRIPTION
A	03/27/05	UPDATE DRAWING FORMAT

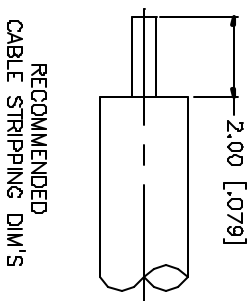
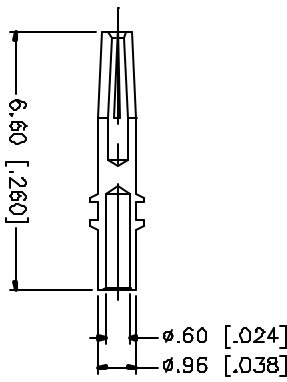
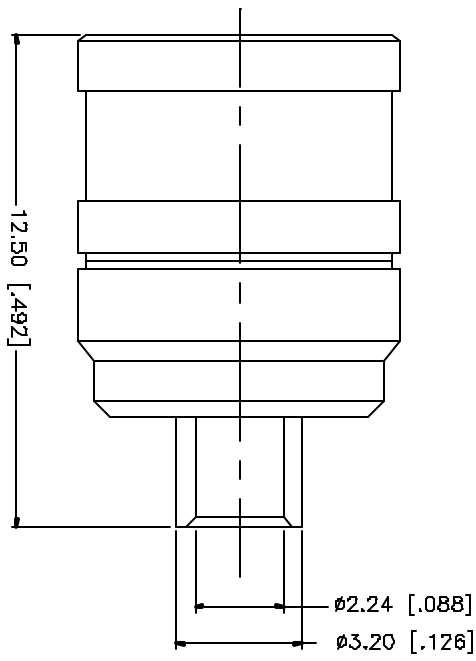

NO.	DESCRIPTION	MATERIAL	FINISH	QTY	VALUES OTHER THAN LISTED DIMENSIONS ARE MINUS AND FOR DIMENSIONS REFERENCE ONLY.	APPROVALS	DATE	PART DESCRIPTION
8								Amphenol Connex
7								
6								SMB DIRECT SOLDER PLUG (FOR .085" , .086")
5								
4								1 42212
3	CONTACT PIN	BRASS	GOLD	1	VALUES OTHER THAN LISTED DIMENSIONS FOR MINUS ARE			
2	INSULATOR	TEFLON	NATURAL	1	VALUES OTHER THAN LISTED DIMENSIONS FOR MINUS ARE			
1	BODY	BRASS	GOLD	1	.020 - .316 ± ± 0.007" .316 - 1.180 ± ± 0.015" 1.180 - 4.724 ± ± 0.020"			
DESCRIPTION								DWG. NO. 142212.DWG
MATERIAL								REV. A
FINISH								SIZE A
QTY								SCALE NA
DO NOT SCALE DRAWING								
DRAWN		G.R.S.		03/27/05				
CHECKED								
ISSUED								
SHEET		1 OF 1						
DWG. FILE		C:/142/142212.DWG						