

1		
Description	Material	Finish
Body	Brass	Gold
Socket	BE CU	Gold
Insulation	Teflon	Teflon
Crimp Ring	Brass	Gold
Snaps	BE CU	Gold

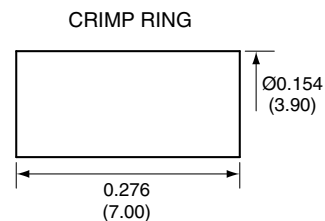

RECOMMENDED CABLE STRIPPING DIMENSIONS

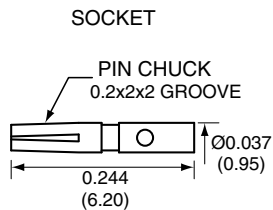
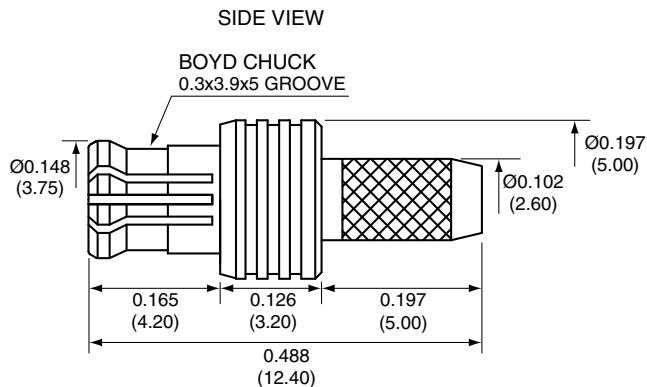
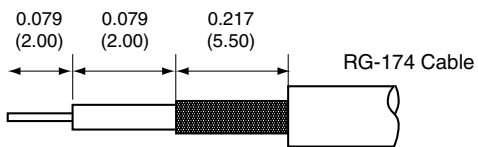

CONREVMCX007 ASSEMBLY INSTRUCTIONS

1. Solder the socket to the center conductor.
2. Insert the socket, center conductor, and insulator into the body until the socket snaps in.
3. Wrap the braid around the tail of the body and crimp the ring with a 0.137" hex crimp tool (or one labeled for use with RG-174 cable)

Title RP-MCX MALE CABLE END CRIMP FOR RG174 CABLE		CONNECTOR CITY 159 ORT LANE MERLIN, OR 97532	
Part No. CONREVMCX007	Revision: 1.0	PH (541)-471-6256 FAX (541)-471-6251	
Dimensions: INCHES (mm)	Date: 6/9/2006	Sheet 1 of 1	

CONNECTOR CITY
THE VALUE OF CONNECTIONS