

REV.	DATE	DESCRIPTION
NC	06/21/07	INITIAL RELEASE

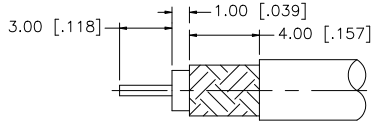

RECOMMENDED  
CABLE STRIPPING DIM'S

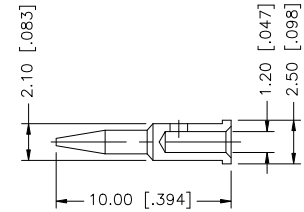
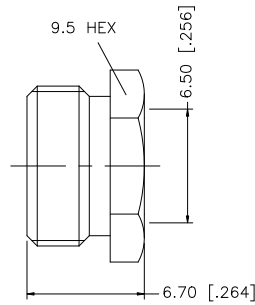
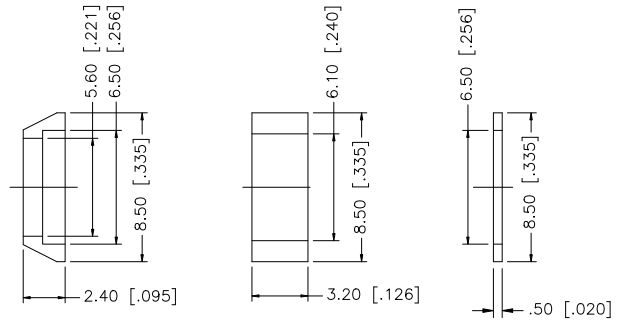
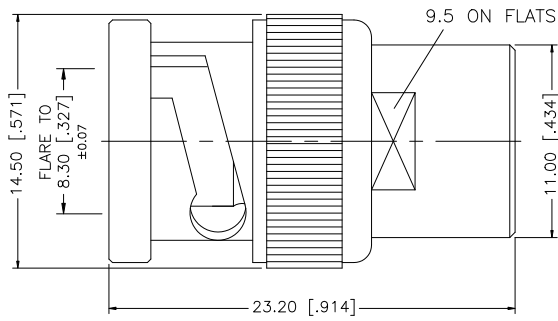

NOTE:  
1. CRIMPED CONTACT PIN  
HEX CRIMP SIZE .068"

8				
7	CONTACT PIN	BRASS	GOLD	1
6	HEX NUT	BRASS	NICKEL	1
5	WASHER	BRASS	NICKEL	1
4	GASKET	SILICONE	RED	1
3	TOP HAT	BRASS	NICKEL	1
2	INSULATOR	DELTRIN	NATURAL	1
1	BODY/SHELL	BRASS	NICKEL	1
	DESCRIPTION	MATERIAL	FINISH	QTY

UNLESS OTHERWISE SPECIFIED DIMENSIONS ARE IN MILLIMETERS; DIMENSIONS IN [ ] ARE IN INCHES AND FOR CUSTOMER REFERENCE ONLY.

UNLESS OTHERWISE SPECIFIED TOLERANCES FOR MILLIMETERS ARE:  
0.5 - 8mm ± 0.20mm  
8 - 30mm ± 0.40mm  
30 - 120mm ± 0.50mm

UNLESS OTHERWISE SPECIFIED TOLERANCES FOR INCHES ARE:  
.020 - .315 = ± 0.007"  
.315 - 1.180 = ± 0.015"  
1.180 - 4.724 = ± 0.020"

DO NOT SCALE DRAWING

APPROVALS	DATE
DRAWN G.R.S.	06/21/07
CHECKED	
ISSUED	
SHEET 1 OF 1	
CAD FILE C:/112/112351.DWG	

# Amphenol Connex

PART DESCRIPTION	BNC CLAMP PLUG (FOR RG-59/U CABLE)		
PART NO.	112351		
DWG. NO.	112351.DWG	REV.	NC
SIZE	A	SCALE	NA