

REV.	DATE	DESCRIPTION
NC	10/04/07	INITIAL RELEASE

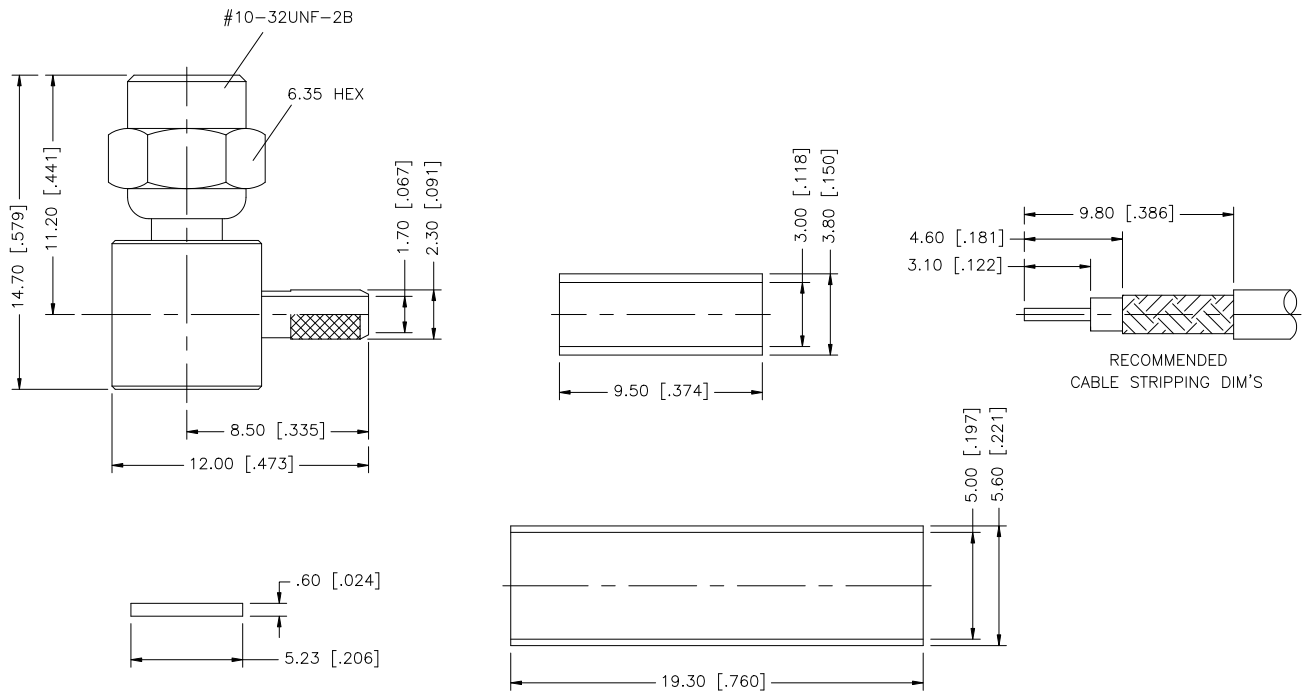

NOTE:
 1. CRIMPED FERRULE HEX CRIMP SIZE .128"
 2. CONTACT PIN TO SOLDER.

				UNLESS OTHERWISE SPECIFIED DIMENSIONS ARE IN MILLIMETERS. DIMENSIONS IN [] ARE IN INCHES AND FOR CUSTOMER REFERENCE ONLY.	APPROVALS	DATE	Amphenol Connex				
8					DRAWN	G.R.S.					10/04/07
7	HEAT SHRINK TUBE			1	CHECKED			PART NO. 152107			
5	FERRULE	COPPER	GOLD	1	ISSUED						
4	COVER	BRASS	GOLD	1	SHEET	1 OF 1		REV. NC	SIZE A	SCALE NA	
3	CONTACT PIN	BER. COPPER	GOLD	1	DO NOT SCALE DRAWING						
2	INSULATOR	TEFLON	NATURAL	1							
1	BODY	BRASS	GOLD	1	CAD FILE C:/152/152107.DWG						
DESCRIPTION	MATERIAL	FINISH	QTY								

UNLESS OTHERWISE SPECIFIED DIMENSIONS ARE IN MILLIMETERS. DIMENSIONS IN [] ARE IN INCHES AND FOR CUSTOMER REFERENCE ONLY.

UNLESS OTHERWISE SPECIFIED TOLERANCES FOR MILLIMETERS ARE:
 0.5 - 8mm ± 0.20mm
 8 - 30mm ± 0.40mm
 30 - 120mm ± 0.50mm

UNLESS OTHERWISE SPECIFIED TOLERANCES FOR INCHES ARE:
 .020 - .315 = ± 0.007"
 .315 - 1.180 = ± 0.015"
 1.180 - 4.724 = ± 0.020"