

TE PART NUMBER	PREVIOUS PART NUMBER	CABLE TYPE
1050541-1	2001-5031-00	RG-402/U .141 SR Coaxial Cable
1050542-1	2001-5031-02	
1056390-1	SCD, 2001-7941-00, SMA	
1050756-1	2001-7941-00	
1050757-1	2001-7941-02	
1044072-1	SCD, 2001-7941-64, SMA	

Figure 1

1. INTRODUCTION

This instruction sheet contains the assembly procedures for the SMA Straight Cable Plug Connectors shown in Figure 1. These connectors are direct solder attachment type connectors that attach to the cable type listed in Figure 1. Figure 1 also contains the previous SMA Straight Cable Plug part numbers.

NOTE

Dimensions on this sheet are in millimeters [with inches in brackets], unless otherwise specified. Figures are not drawn to scale.

The table in Figure 2 references the tools required to apply these connectors. The table includes tool descriptions, TE Connectivity (TE) part numbers, and the corresponding previous part numbers.

Reasons for re-issue can be found in Section 3, REVISION SUMMARY.

Read and understand these instructions thoroughly before proceeding.

2. ASSEMBLY PROCEDURES

2.1. Preparing the Cable

Trim the cable end square (90° angle), as shown in Figure 3. Remove the burrs.

APPLICATION TOOLING		
Tool Description	TE Part Number	Previous Part Number
Fixture Base	1055439-1	2098-5206-54 (T-5467)
Clamp Insert	1055440-1	2098-5207-54 (T-4700-1)
Locator Tool	1055442-1	2098-5209-02 (T-4575)
Dielectric Recess Tool	1055450-1	2098-5217-54 (T-4582)
Trim Tool (Optional)	1055455-1	2098-5222-02 (T-5699)
Retaining Ring Pliers	1055449-1	2098-5216-54 (T-5702)

Figure 2

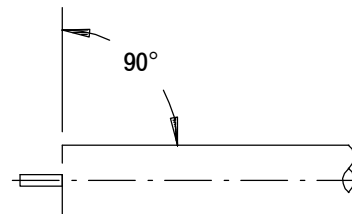

Figure 3

2.2. Soldering Cable to Plug Housing (Figure 4)

1. Place plug housing on the end of the cable.
2. Place the loose assembly in the fixture base described in Figure 2.
 - a. Nest the cable end in the locator tool.
 - b. Tighten the clamp screw to secure the cable.
 - c. Tighten the locator tool to seat the cable firmly.
3. Slide the housing against the locator tool.
4. Hold the the housing firmly against the locator tool and solder as shown in Figure 4 with 60/40 solder.

DANGER

Solder equipment is hot. To avoid personal injury, be sure to exercise caution and follow all local safety procedures when using soldering equipment.

2.3. Compressing the Expanded Dielectric

1. Trim the extended or exposed dielectric flush with the end of the cable outer conductor.
2. Place the dielectric recess tool on the dielectric and push the tool to recess the dielectric within the cable outer conductor. See Figure 5.

2.4. Removing the Outer Conductor and Dielectric

1. Insert the squared cable end into the fixture base hole (hole pattern No. 1).
2. Place the saw in the saw slot and cut through the the outer conductor and into the dielectric while rotating the cable.
3. Remove the cable from the the fixture base and finish cutting the dielectric with a cutting blade.

DANGER

To avoid personal injury, be sure to wear gloves and follow all local safety practices when using a cutting blade.

4. Bare the inner conductor by prying out the outer conductor and dielectric from the cable.

2.5. Trimming the End of Housing Subassembly (Optional)

1. Place the trim tool (see Figure 2) over the inner conductor projection and rotate to face off the front face.
2. Inspect for the dimensions shown in Figure 7.

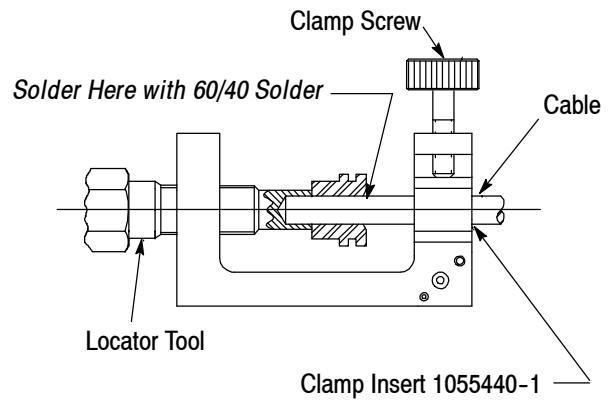

Figure 4

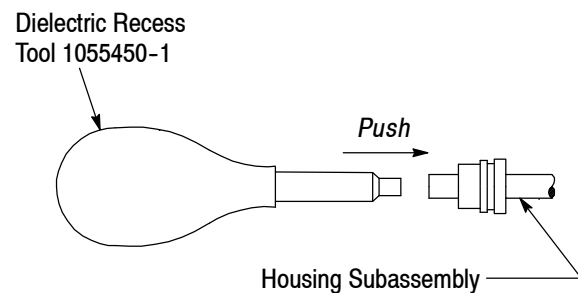

Figure 5

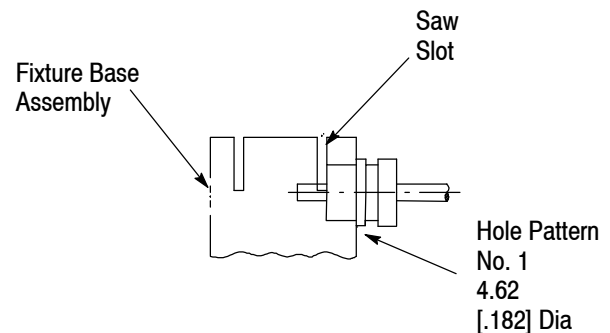

Figure 6

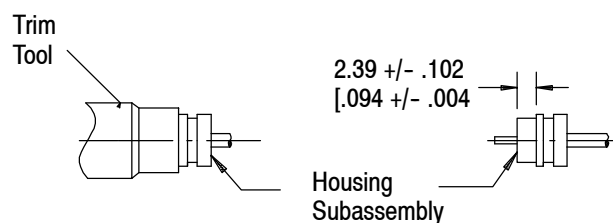

Figure 7

2.6. Shaping the Inner Conductor

1. Trim the inner conductor to the length indicated in Figure 8.
2. File the blunt end of the inner conductor to a 75° to 90° cone.

2.7. Securing Coupling Nut to Housing (Figure 9)

1. Place the retaining ring and gasket on the housing.
2. Compress the retaining ring with the retaining ring pliers (refer to Figure 2).
3. Push the coupling nut onto the housing.

NOTE *The coupling nut should rotate freely.*

3. REVISION SUMMARY

- Updated document to corporate requirements
- New logo

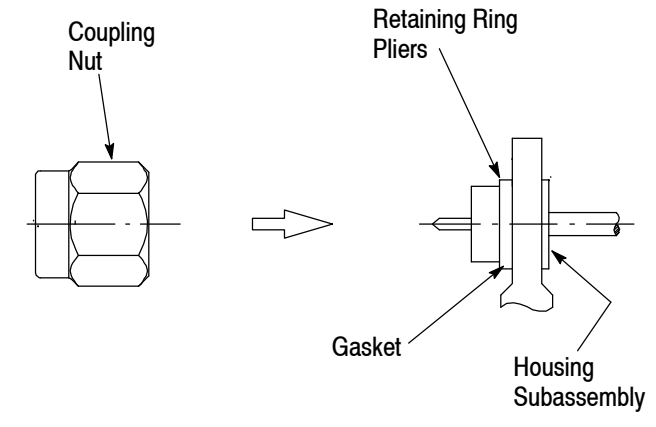

Figure 9

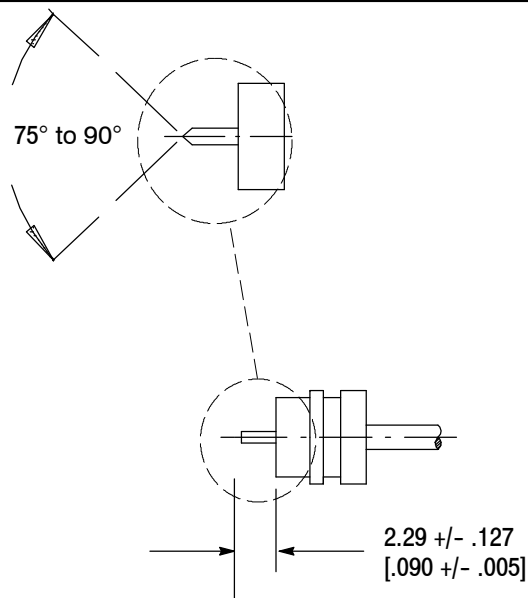

Figure 8