

NOTES:

- MATERIALS OF CONSTRUCTION:
SHELL, BODY = BRASS (ASTM-B16 H02, C36000), GOLD PLATED (.000003 MIN) THICK.
CONTACT = BRASS (ASTM-B16 H02, C36000), GOLD PLATED (.000050 MIN) THICK.
RETAINING RING = BERYLLIUM COPPER (QQ-C-530), NATURAL.
GASKET = SILICONE RUBBER, COLOR RED.
INSULATOR = PTFE, ASTM D 1710 OR EQUIV.
FERRULE = JIS H 3250, C 2600, GOLD PLATED (.000003 MIN) THICK.
- DO NOT SCALE THIS DRAWING.
- UNLESS OTHERWISE SPECIFIED, ALL DIMENSIONS ARE AFTER PLATING.

901-10009-RFX		REVISIONS			
DRAWING NO.	REV	DESCRIPTION	DATE	ECO	APPR
THIRD ANGLE PROJ.	A	RELEASE TO MFG.	3/11/99	42865	CPM/
	B	SEE SHEET 1	9-21-02	44182	CPM/

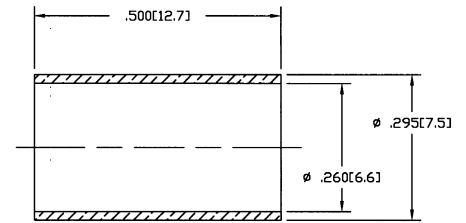
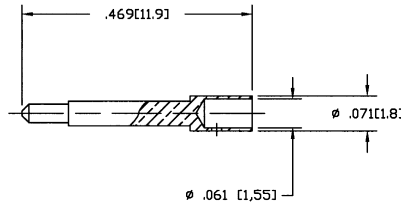
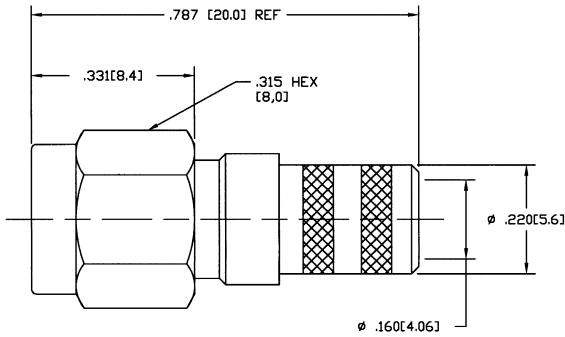

CUSTOMER OUTLINE DRAWING
ALL OTHER SHEETS ARE FOR INTERNAL USE ONLY

CABLE STRIPPING DIMENSIONS

<p>UNLESS OTHERWISE SPECIFIED, DIMENSIONS ARE IN INCHES AND TOLERANCES ARE: 2 PLACE DECIMAL 3 PLACE DECIMAL ±.015 (0.381 mm) ±.005 (0.127 mm)</p> <p>NOTICE - These drawings, specifications, or other data (1) are, and remain the property of Amphenol Corp. (2) must be returned upon request; and (3) are confidential and not to be disclosed to any person other than those to whom they are given by Amphenol Corp. The furnishing of these drawings, specifications, or other data by Amphenol Corp., or to any other person to anyone for any purpose is not to be regarded by implication or otherwise in any manner licensing, granting rights or permitting such holder or any other person to manufacture, use or sell any product, process or design, patented or otherwise, that may in any way be related to or disclosed by said drawings, specifications, or other data.</p>	MATERIAL	<p>DRAWN C. McGRATH DATE 2/23/99</p> <p>ENGINEER P. BRENZEL DATE 2/23/99</p> <p>APPROVED T. AUBIN DATE 3/9/99</p>	TITLE	<p>Amphenol Amphenol Corporation RF/Microwave Operations Danbury, Conn. U.S.A. 06810</p>	
	REFERENCE	<p>CODE ID DWG SIZE DRAWING NO. SCALE: 5:1 SHEET 2 OF 2 REV</p> <p>H:\PETE\SMA\901\ASSY\10009\RFXSH2 74868 B 901-10009-RFX B</p>	<p>SMA CRIMP PLUG FOR 8X LMR 240 CABLE</p>		