

PROPER USE GUIDELINES

Cumulative Trauma Disorders can result from the prolonged use of manually powered hand tools. Hand tools are intended for occasional use and low volume applications. A wide selection of powered application equipment for extended-use, production operations is available.

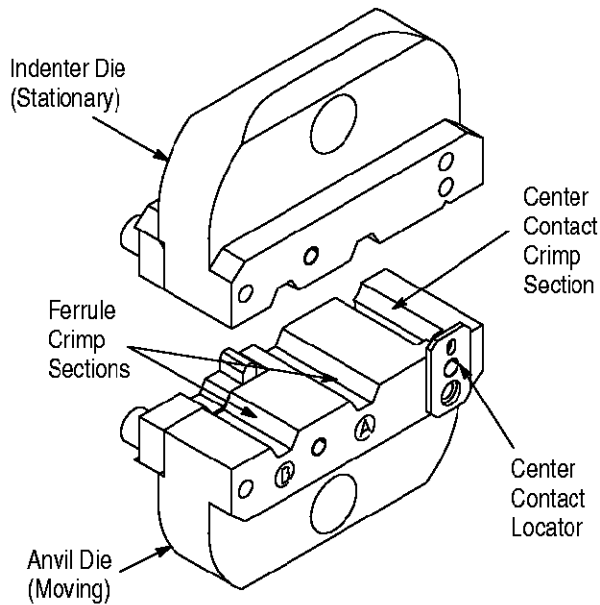

Figure 1

1. INTRODUCTION

This instruction sheet covers the use and maintenance of AMP* Crimping Die Assembly 58046-1, which is used in PRO-CRIMPER* II Hand

Tool Frame Assembly 354940-1. The die assembly crimps various configurations of Commercial SMB Connectors onto coaxial cable.

Catalog 82074 provides a guide for cable-to-connector selection. For cable sizes and connectors not referenced in the catalog, contact Product Engineering for connector recommendations.

NOTE

All dimensions on this document are in metric units [with U.S. customary units in brackets].

Reasons for reissue are provided in Section 7, REVISION SUMMARY.

2. DESCRIPTION (Figure 1)

Each die assembly consists of an indenter die and an anvil die, and includes a center-contact crimp section and a center-contact locator. The die assembly features two large crimp sections for ferrules.

3. DIE INSTALLATION

1. Close the tool handles until the ratchet releases, then allow the handles to open fully.
2. Insert the dies into the tool jaws as shown in Figure 2, and align the retaining holes in each die with the associated holes in the tool frame.

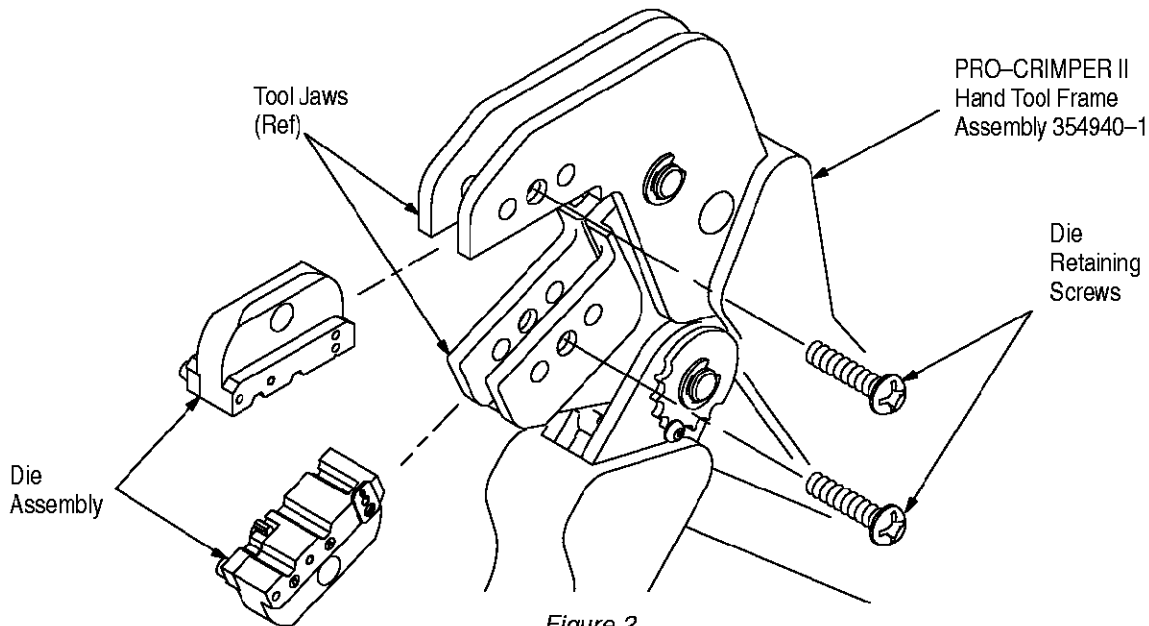

Figure 2

3. Thread, but do not tighten, the die retaining screws into the holes.
4. Carefully close the tool handles, making sure that the dies align properly.
5. Tighten the die retaining screws securely.

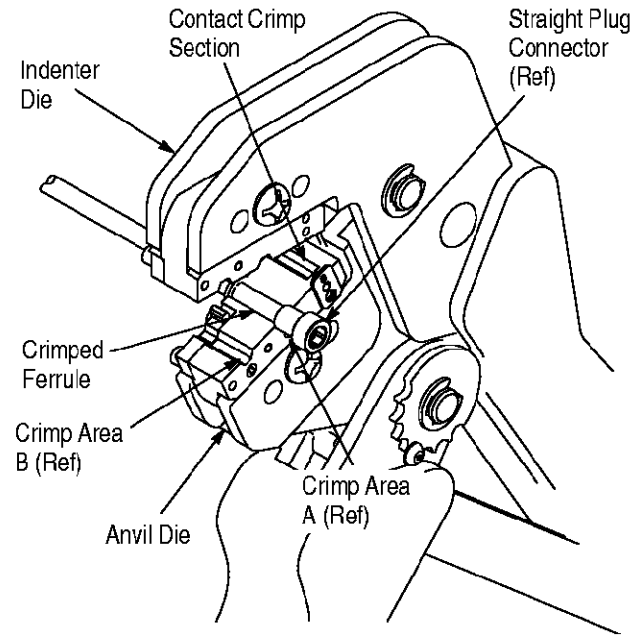

Figure 3

4. CRIMPING PROCEDURE (Figure 3)

NOTE This tool will not provide a crimp conforming to military requirements, nor can it be used on MIL-type connectors.

NOTE Refer to the appropriate instruction sheet, packaged with the connectors, for cable stripping dimensions and connector assembly procedures.

Slide ferrule onto the cable and strip cable according to specified dimensions. Flare braid and proceed as follows:

1. Crimp center conductor:
 - a. **Straight Plug Connector** (Figure 4A)
Place contact in center contact crimp section, making sure the contact bottoms against the locator. Insert center conductor into center contact. To crimp the contact, close the tool handles until the ratchet releases. Open tool handles fully to remove crimped contact.
 - b. **Right-Angle Plug Connector** (Figure 4B)
Position conductor in slot of captive contact, ensuring that shielding is over connector's support sleeve. Solder center conductor to captive contact as described in Instruction Sheet

408-2987-5. Place contact in contact crimp section, making sure the contact bottoms against the locator. To crimp the contact, close the tool handles until the ratchet releases. Open tool handles fully to remove crimped contact.

c. **Jack and Bulkhead Jack Connectors**
(Figures 4C and 4D)

Place contact in contact crimp section making sure the contact bottoms against the locator. Insert center conductor into center contact. To crimp the contact, close the tool handles until the ratchet releases. Open tool handles fully and remove crimped contact.

SMB Connector Kits

A Straight Plug Kit 228213, 413985, 414946 Series

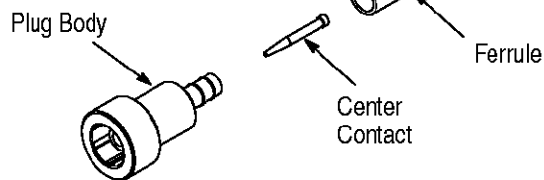

B Right-Angle Plug Kit 228214, 414363 Series

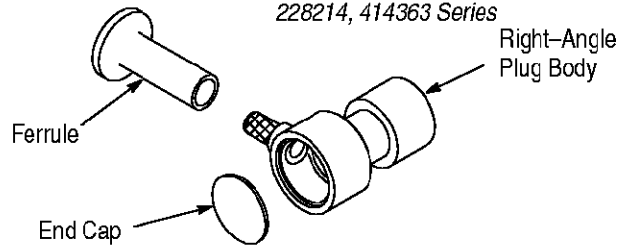

C Jack Connector Kit 414170 Series

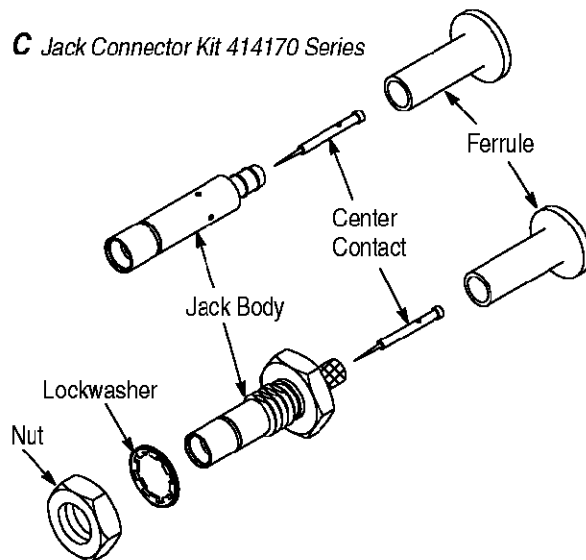

D Bulkhead Jack Connector Kit 228217 Series

Figure 4

2. Insert crimped contact assembly into the connector. Slide the ferrule forward over the braid and support sleeve as described in the appropriate instruction sheet packaged with the connector.

3. Insert connector ferrule into proper crimp area.

NOTE When using RG-178/U or RG-196/U cable, place ferrule in crimp area B. For all other cable sizes, use crimp area A.

4. Slide ferrule and contact through the crimp area until the ferrule flange bottoms against the die to prevent damage to the connector. Close tool handles until the ratchet releases.

5. Open tool handles fully to remove crimped connector assembly.

5. MAINTENANCE AND INSPECTION

5.1. Daily Maintenance

1. Remove dust, moisture, and other contaminants with a clean, soft brush, or a clean, soft, lint-free cloth. Do NOT use any objects that could damage the dies or tool.

2. Make sure that the proper die retaining screws are properly secured.

3. When the dies are not in use, store them in a clean, dry area. When the tool is not in use, store it with the handles closed to prevent objects from becoming lodged within the jaws.

5.2. Visual Inspection

1. Remove all lubrication and accumulated film from the dies by immersing the dies in a suitable commercial degreaser.

2. Make certain that all die retaining screws and die components are properly secured.

3. Inspect the crimping surfaces for flattened, chipped, worn, or cracked areas. If damage is evident, the dies must be replaced. Refer to Section 6, REPLACEMENT.

5.3. Measuring Die Opening

The die assembly will perform correctly as long as: (1) the product specified is correct for the application, (2) the specific die assembly is used, (3) the die assembly has been measured to ensure that the openings are correct, and (4) the die assembly bottoms.

Figure 5 provides information on die opening sizes.

For specific applications where wire stiffness, material, or insulation may give different than standard performance, it may be necessary to

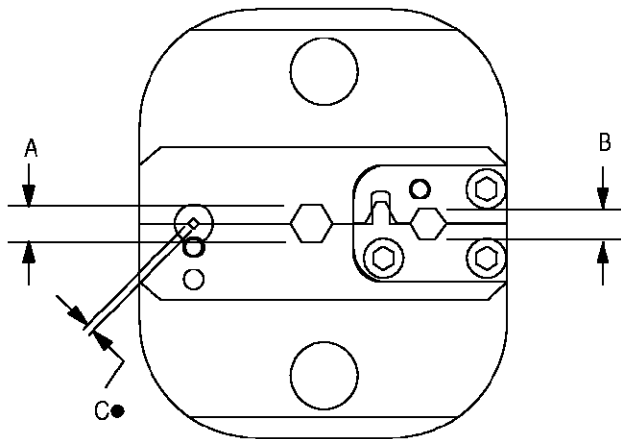

DIE ASSEMBLY	DIE OPENING (mm [in.])		
	A	B	C●
58046-1	3.00 ± 0.08 [.118 ± .003]	2.39 ± 0.10 [.094 ± .004]	0.610 - 0.673 [.0240 - .0265]

●NOTE: Alternate method to check "C" dimension is to crimp #20 AWG solid wire, and measure the crimp height. One side may be 0.051 [.0020] out of tolerance, as long as the average measurements of both sides are within the dimension specified.

Figure 5

measure the crimped ferrule, rather than to verify the size of the die opening. This inspection requires the use of a cone or modified micrometer (Crimp Height Comparator RS-1019-5LP), which is available from:

Shearer Industrial Supply Co. VALCO
20 North Penn Street or 1410 Stonewood Drive
York, PA 17401-1014 Bethlehem, PA 18017-3527

5.4. Ratchet Adjustment (Figure 6)

The tool frame assembly ratchet mechanism features an adjustment wheel with numbered settings. If the crimp height is not acceptable, adjust the ratchet as follows:

1. Remove the lock screw from the ratchet adjustment wheel.
2. With a screwdriver, adjust the ratchet wheel from the opposite side of the tool.
3. Observe the ratchet adjustment wheel. If a tighter crimp is required, rotate the adjustment wheel COUNTERCLOCKWISE to a higher-numbered setting. If a looser crimp is required, rotate the adjustment wheel CLOCKWISE to a lower-numbered setting.
4. Replace the lock screw.
5. Make a sample crimp and measure the crimp height. If the crimp height is acceptable, secure the lock screw. If the dimension is unacceptable, remove lock screw and continue to adjust the ratchet, and again measure a sample crimp.

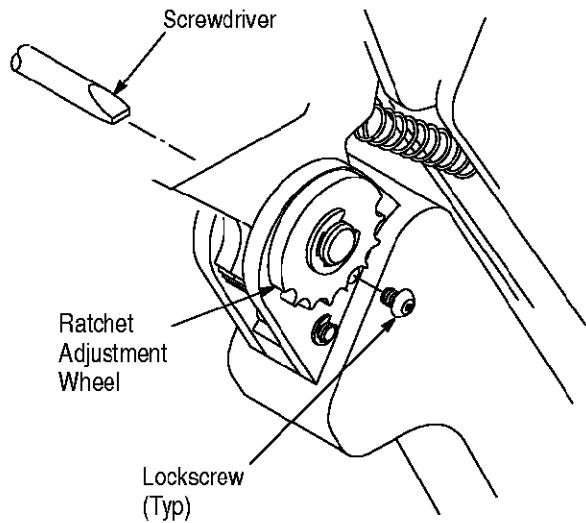

Figure 6

6. REPLACEMENT

Customer-replaceable parts are listed in Figure 7. A complete inventory should be stocked and controlled

to prevent lost time when replacement of parts is necessary. Order replacements through your Tyco Representative, or call 1-800-526-5142, or send a facsimile of your purchase order to 1-717-986-7605, or write to:

CUSTOMER SERVICE (38-35)
TYCO ELECTRONICS CORPORATION
P.O. BOX 3608
HARRISBURG, PA 17105-3608

For customer repair service, please contact a representative at 1-800-526-5136.

7. REVISION SUMMARY

Revisions to this instruction sheet per EC: 0990-0815-00 include:

- Updated document to corporate requirements
- Deleted obsolete catalog reference in Section 1
- Updated kit part numbers in Figure 4
- Added new note to Figure 5
- Changed address information in Section 6

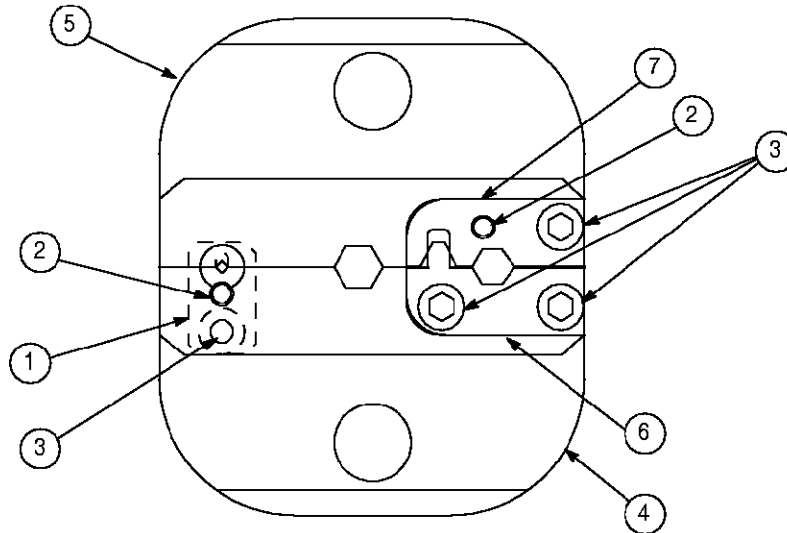

REPLACEMENT PARTS

ITEM	PART NUMBER	DESCRIPTION	QUANTITY PER ASSEMBLY
1	312224-1	LOCATOR	1
2	21028-2	PIN, Slotted Spring	2
3	1-21000-0	SCREW, Socket head Cap	4
4	312228-1	CRIMPING DIE, Lower	1
5	312227-1	CRIMPING DIE, Upper	1
6	312226-1	INSULATION INSERT, Lower	1
7	312225-1	INSULATION INSERT, Upper	1

Figure 7