

All rights strictly reserved. Reproduction or issue to third parties in any form whatever is not permitted without written authority from the proprietor. Property of FCI. Copyright FCI.

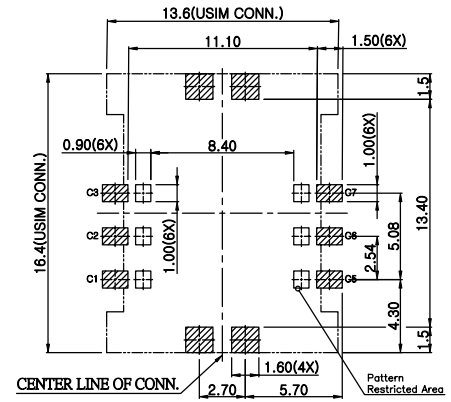

PRODUCT NO.
 10074235-100LF

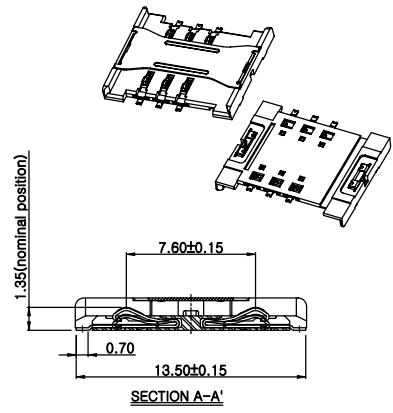
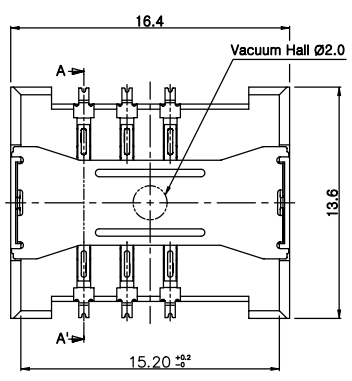

RECOMMENDED P.C.B. LAYOUT (Top View)
 Tolerance : ±0.05

- NOTES :
- MATERIAL
 INSULATOR : HIGH TEMPERATURE THERMOPLASTIC
 FLAMMABILITY RATING, UL94V-0
 COLOR : BLACK
 CONTACT : COPPER ALLOY (t=0.15mm)
 METAL COVER : STAINLESS STEEL (t=0.15mm)
 - PLATING
 CONTACT AREA: 0.3um Min. Au SELECTIVE GOLD
 UNDER PLATING: 1~5um NICKEL OVERALL
 SOLDER TAIL AREA: 0.05um GOLD FLASH NICKEL OVERALL
 METAL COVER: 1~5um NICKEL OVERALL
 - PRODUCT SPEC: GS-12-444.
 - PACKAGE SPEC: GS-14-1156.
 - THIS PRODUCT MEETS THE EUROPEAN UNION DIRECTIVE AS DESCRIBED IN GS-22-008.
 - THE HOUSING WILL WITHSTAND EXPOSURE TO 260°C PEAK TEMPERATURE FOR 10 SECONDS IN A CONVECTION, IR OR VAPOR PHASE REFLOW OVEN.

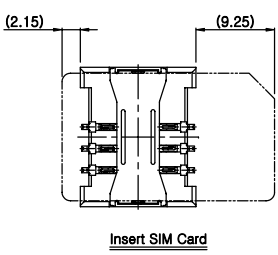
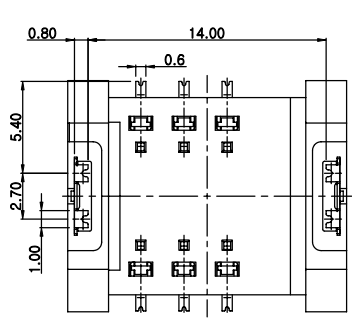
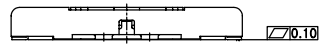
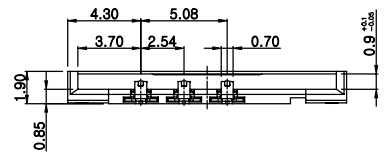

mat'l. code				tolerances unless otherwise specified		CUSTOMER COPY		FCI			
ltr	ecn no	dr	date	linear	.X ± 0.30	projection	title	www.fciconnect.com			
A	T07-1025	WL	03/20/07		.XX ± 0.20		U-SIM CONNECTOR (1.9mm/6 POS.)				
B	T07-1035	WL	04/09/07		.XXX ± 0.10						
C	T07-1059	WL	05/03/07	angles	0° ± 2°		product family USIM CONNECTOR size dwg no				
D	T07-1086	WL	05/28/07	dr	WENDY CHEN 03/08/07			scale A4	10074235		
				enr	ALLEN CHANG 03/08/07						
				chr	ALLEN CHANG 03/08/07						
				appd	ALEX LIANG 03/08/07						
sheet index	revision sheet	D	D								
		1	2								

ACAD PDM: Rev:D 3 STATUS Released 20071016 Oct 16, 2008

All rights strictly reserved. Reproduction or issue to third parties in any form whatever is not permitted without written authority from the proprietor. Property of FCI. Copyright FCI.
 Tous droits strictement réservés. Reproduction ou communication à des tiers interdite sous quelque forme que ce soit sans autorisation écrite du propriétaire. Propriété de FCI. Droits de reproduction FCI.

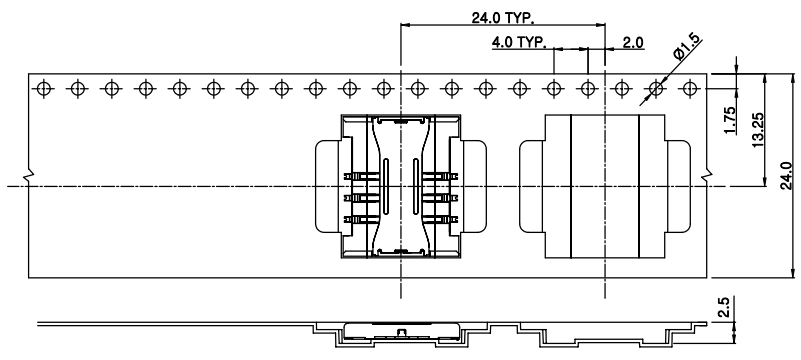

NOTES

1. CARRIER TAPE PACKING LENGTH

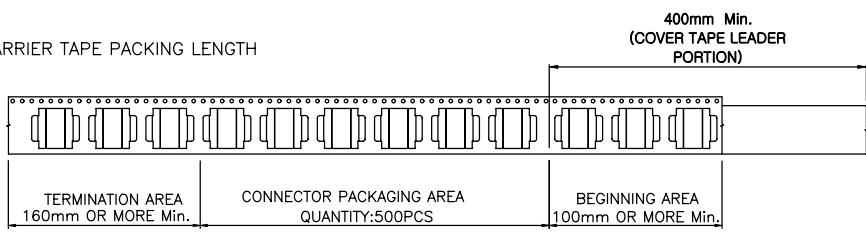

2. CARRIER TAPE DIRECTION:

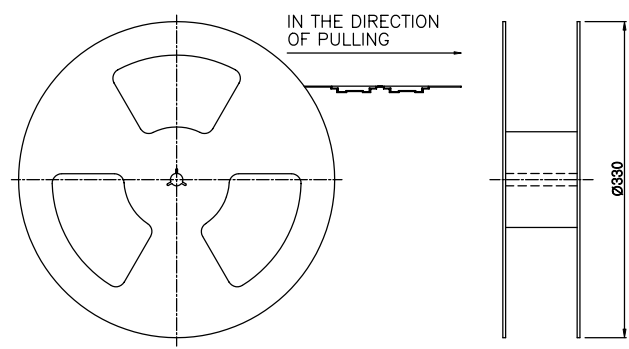

- 3. PEELING FORCE : 10 ~ 132g
- 4. MATERIAL:
 CARRIER TAPE: PS, t=0.4mm.
 COVER TAPE : PE
 PLASTIC HUB: PS

mat'l. code				tolerances unless otherwise specified		CUSTOMER COPY	FCI		www.fciconnect.com	
ltr	ecn no	dr	date	linear	.X ± 0.30	projection	title	product family	USIM CONNECTOR	code
D					.XX ± 0.20					
					.XXX ± 0.10					
				angles	0° ± 2'					
				dr	WENDY CHEN D3/08/07					
				enr	ALLEN CHANG D3/08/07					
				chr	ALLEN CHANG D3/08/07					
				appd	ALEX LIANG D3/08/07					
sheet index	revision sheet									

ACAD PDM: Rev:D 3 STATUS Released 2008 Oct 16, 2008 cage code 20526 4