

Customer Information Sheet

DRAWING No. M60-605XX45

SHEET 2 OF 2

IF IN DOUBT - ASK

(C)

NOT TO SCALE

THIRD ANGLE PROJECTION

ALL DIMENSIONS IN mm

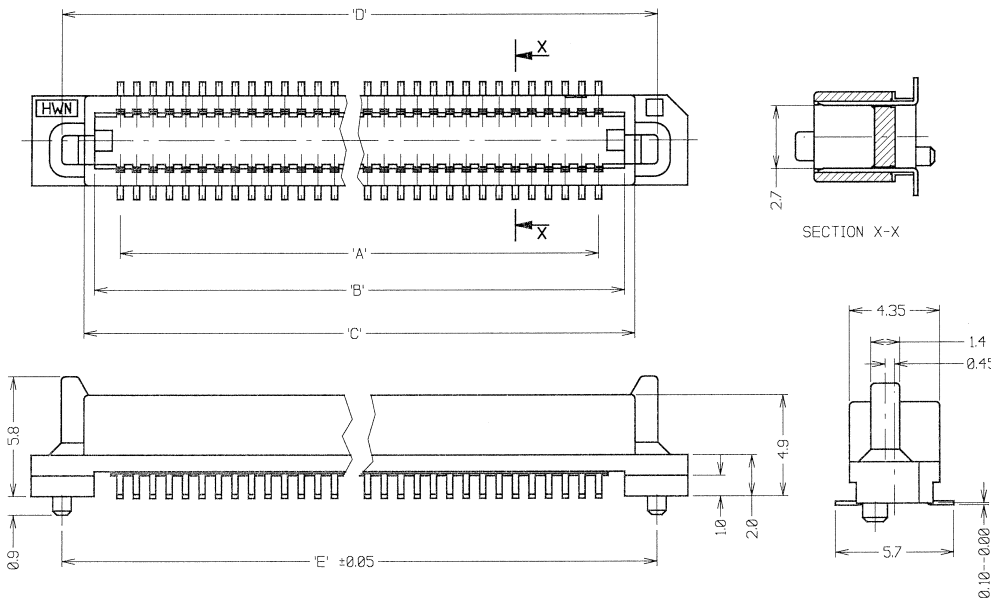

PART No.	No. OF CONTACTS	'A'	'B'	'C'	'D'	'E'	'F'
M60-6051045	10 + 10	7.2	9.7	10.7	12.9	12.8	15.8
M60-6051545	15 + 15	11.2	13.7	14.7	16.9	16.8	19.8
M60-6052045	20 + 20	15.2	17.7	18.7	20.9	20.8	23.8
M60-6052545	25 + 25	19.2	21.7	22.7	24.9	24.8	27.8
M60-6053045	30 + 30	23.2	25.7	26.7	28.9	28.8	31.8
M60-6054045	40 + 40	31.2	33.7	34.7	36.9	36.8	39.8
M60-6055045	50 + 50	39.2	41.7	42.7	44.9	44.8	47.8

SPECIFICATIONS:

MATERIAL:
 MOULDING = LCP, UL94V-0
 CONTACTS = PHOSPHOR BRONZE

FINISH:
 CONTACTS:
 0.05µ MIN GOLD OVER 1.27µ MIN NICKEL
 0.5µ MIN GOLD ON CONTACT AREA.

ELECTRICAL:
 CURRENT RATING = 0.5 AMPS
 VOLTAGE RATING = 100V AC
 DIELECTRIC WITHSTANDING VOLTAGE = 300V AC (1 MINUTE)
 INSULATION RESISTANCE = 1000 MEGOHMS MIN (250V DC)
 CONTACT RESISTANCE = 40 MILLIOHMS MAX

MECHANICAL:
 DURABILITY = 30 CYCLES

ENVIRONMENTAL:
 TEMPERATURE RANGE = -55°C TO +100°C
 PACKING = TUBE

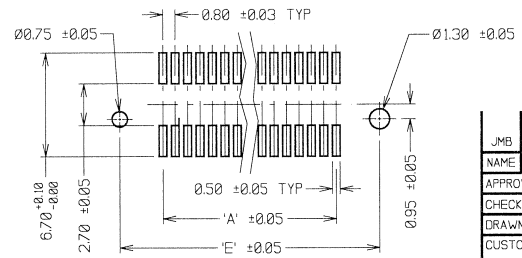
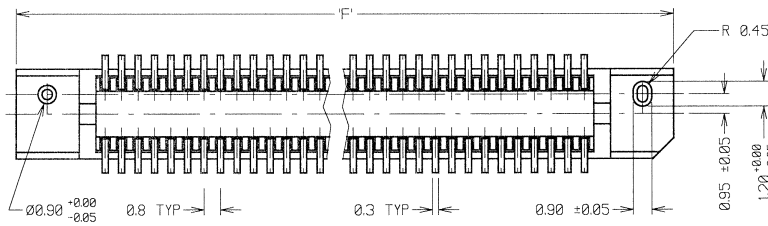

JMB	8	17.07.06	9324
NAME	ISS.	DATE	C/NOTE
APPROVED:			
CHECKED:			
DRAWN: WJ BOURNE			
CUSTOMER REF.:			
ASSEMBLY DRG.:			

- NOTES:**
- MATES WITH M60-614XX45 OR M60-616XX45 TO GIVE BOARD-TO-BOARD HEIGHTS OF 6mm AND 8mm RESPECTIVELY.
 - ALL TOLERANCES ±0.30 UNLESS OTHERWISE STATED.

ORDER CODE:
M60-605XX45

No. OF CONTACTS
 10, 15, 20, 25, 30, 40, 50

HARWIN			THIS DRAWING AND ANY INFORMATION OR DESCRIPTIVE MATTER SET OUT HEREON ARE CONFIDENTIAL AND COPYRIGHT PROPERTY OF THE HARWIN GROUP AND MUST NOT BE DISCLOSED, LOANED, COPIED OR USED FOR MANUFACTURING, TENDERING OR FOR ANY OTHER PURPOSE WITHOUT THEIR WRITTEN PERMISSION.	TOLERANCES XX = ±0.1mm XX = ±0.25mm XXX = ±0.10mm XXXX = ±0.01mm ANGLES = ±5° UNLESS STATED	MATERIAL: SEE ABOVE	TITLE: 0.80mm PITCH SMT SOCKET CONNECTOR (5mm HIGH)
HARWIN USA TEL: 803 893 5370 FAX: 803 893 5336 mls@harwin.com	HARWIN Europe (UK) TEL: 023 9231 4545 FAX: 023 9231 4500 mls@harwin.co.uk	HARWIN Asia TEL: +85 6 779 4909 FAX: +85 6 779 3868 mls@harwin.com.sg		FINISH: SEE ABOVE S/AREA: mm ²	DRAWING NUMBER: M60-605XX45	SHT 2 OF 2