

Customer Information Sheet

DRAWING No.: M30-9040099-M30-9070099 2 OF 2 IF IN DOUBT - ASK © NOT TO SCALE THIRD ANGLE PROJECTION ALL DIMENSIONS IN mm

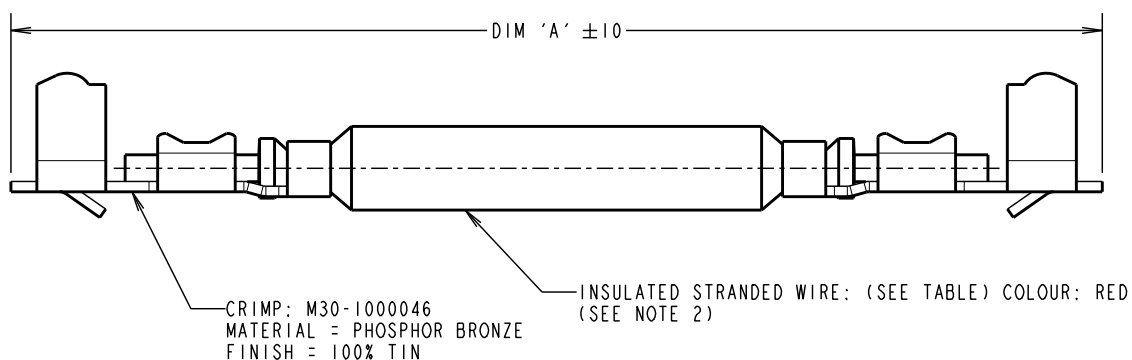

PART No.	AWG	DIM 'A'	WIRE TYPE
M30-9000099	26	150	BS3G210 TYPE A PTFE INSULATED
M30-9010099	30	150	UL STYLE 1213
M30-9020099	26	300	BS3G210 TYPE A PTFE INSULATED
M30-9030099	30	300	UL STYLE 1213

RA	5	24.05.11	11277
NAME	ISS.	DATE	C/NOTE
APPROVED:		R.ADDE	
CHECKED:		M.G.PLESTED	
DRAWN:		J.ENRIGHT	
CUSTOMER REF.:			
ASSEMBLY DRG:			

- NOTES:
 1. TO BE USED WITH CRIMP HOUSINGS M30-110XX00 & M30-120XX00.
 2. WIRE & CRIMPS ARE BOTH RoHS COMPLIANT.

HARWIN

HARWIN USA TEL: 603 893 5376 FAX: 603 893 5396 mis@harwin.com	HARWIN Europe (UK) TEL: 023 9231 4545 FAX: 023 9231 4590 mis@harwin.co.uk	HARWIN Asia TEL: +65 6 779 4909 FAX: +65 6 779 3868 mis@harwin.com.sg
--	--	--

THIS DRAWING AND ANY INFORMATION OR DESCRIPTIVE MATTER SET OUT HEREON ARE CONFIDENTIAL AND COPYRIGHT PROPERTY OF THE HARWIN GROUP AND MUST NOT BE DISCLOSED, LOANED, COPIED OR USED FOR MANUFACTURING, TENDERING OR FOR ANY OTHER PURPOSE WITHOUT THEIR WRITTEN PERMISSION.

TOLERANCES
 X. = ±1mm
 X.X = ±0.25mm
 X.XX = ±0.10mm
 X.XXX = ±0.01mm
 ANGLES = ±5°
 UNLESS STATED

MATERIAL: SEE ABOVE
 FINISH: SEE ABOVE
 S/AREA: mm²

TITLE: PRE-CRIMPED CONTACT (M30-1000046)

DRAWING NUMBER: M30-9040099-M30-9070099

SHT 2 OF 2