

# Customer Information Sheet

DRAWING No.: M20-975XXXX

SHEET 2 OF 2

IF IN DOUBT - ASK

©

NOT TO SCALE

THIRD ANGLE PROJECTION

ALL DIMENSIONS IN mm

**NOTES:**

1. RECOMMENDED PCB MOUNTING HOLE SIZE =  $\varnothing 1.00\text{mm}$ .
2. ALL TOLERANCES ARE  $\pm 0.25\text{mm}$  UNLESS OTHERWISE STATED.
3. FOR COMPLETE SPECIFICATION, SEE COMPONENT SPECIFICATION C001XX (LATEST ISSUE).

**SPECIFICATION:**

**MATERIAL:**  
 MOULDING = HIGH TEMP NYLON 6T UL94V-0, BLACK  
 PINS = BRASS  
**FINISH:**  
 PINS:  
 42 = GOLD ON CONTACT AREA, 100% TIN ON TAILS  
 46 = 100% TIN OVER NICKEL  
**ELECTRICAL:**  
 CURRENT RATING = 3A MAX  
 CONTACT RESISTANCE = 25 m $\Omega$  MAX (GOLD), 30 m $\Omega$  MAX (TIN)  
 INSULATION RESISTANCE = 1,000 M $\Omega$  MIN  
 DIELECTRIC STRENGTH = 750V AC/DC  
**MECHANICAL:**  
 DURABILITY = 300 OPERATIONS (GOLD), 50 OPERATIONS (TIN)  
**ENVIRONMENTAL:**  
 TEMPERATURE RANGE = -40°C TO +105°C  
**PACKING:**  
 BAG

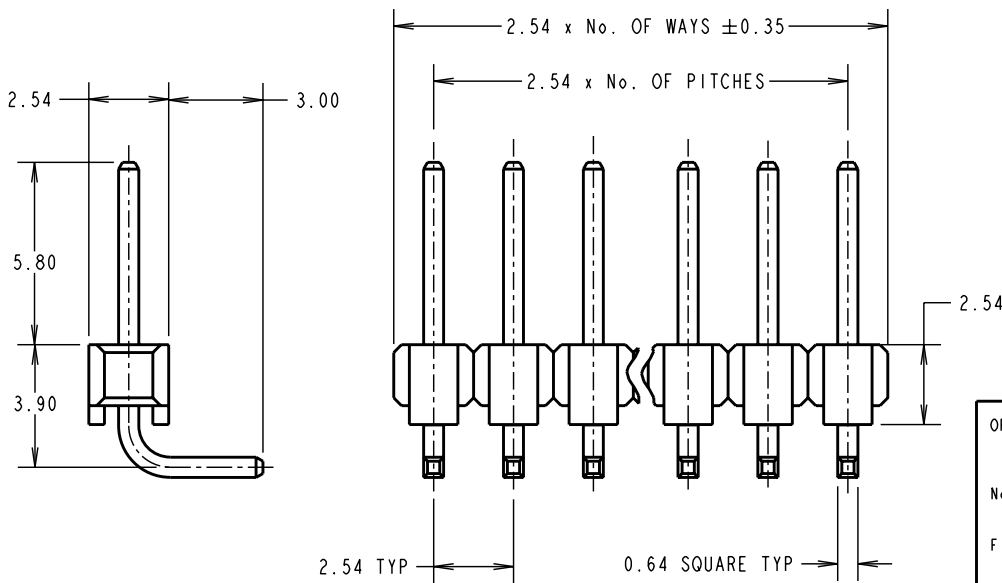

ORDER CODE:  
**M20-975XXXX**  
 No. OF WAYS: 02 TO 40  
 FINISH:  
 42 = SELECTIVE GOLD + 100% TIN  
 46 = 100% TIN

CP	I3	14.09.09	10298
NAME	ISS.	DATE	C/NOTE
APPROVED: C. PENROSE			
CHECKED: R. ADDE			
DRAWN: J. CLAY			
CUSTOMER REF.:			
ASSEMBLY DRG:			

**HARWIN**

HARWIN USA  
 TEL: 603 893 5376  
 FAX: 603 893 5396  
 mis@harwin.com

HARWIN Europe (UK)  
 TEL: 023 9231 4545  
 FAX: 023 9231 4590  
 mis@harwin.co.uk

HARWIN Asia  
 TEL: +65 6 779 4909  
 FAX: +65 6 779 3868  
 mis@harwin.com.sg

THIS DRAWING AND ANY INFORMATION OR DESCRIPTIVE MATTER SET OUT HEREON ARE CONFIDENTIAL AND COPYRIGHT PROPERTY OF THE HARWIN GROUP AND MUST NOT BE DISCLOSED, LOANED, COPIED OR USED FOR MANUFACTURING, TENDERING OR FOR ANY OTHER PURPOSE WITHOUT THEIR WRITTEN PERMISSION.

**TOLERANCES**  
~~X =  $\pm 1\text{mm}$~~   
~~X.X =  $\pm 0.25\text{mm}$~~   
~~X.XX =  $\pm 0.10\text{mm}$~~   
~~X.XXX =  $\pm 0.01\text{mm}$~~   
 ANGLES =  $\pm 5^\circ$   
 UNLESS STATED

**MATERIAL:**  
 SEE ABOVE  
**FINISH:**  
 SEE ABOVE  
**S/AREA:**  
 mm<sup>2</sup>

**TITLE:** 2.54mm PITCH SIL HORIZONTAL PC TAIL PIN HEADER ASSEMBLY  
**DRAWING NUMBER:** M20-975XXXX  
 SHT 2 OF 2