

PRODUCT NO.
SEE TABLE

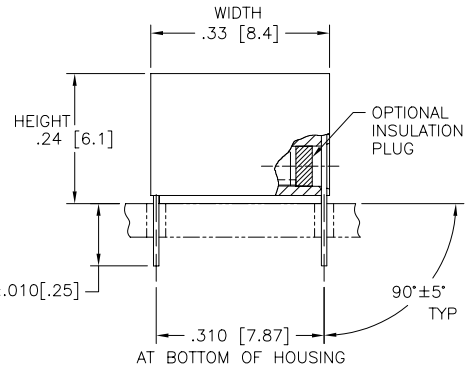
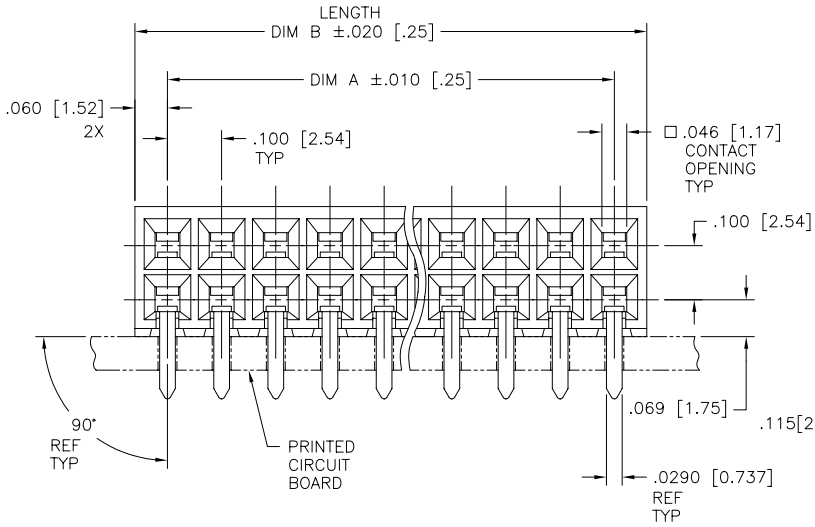
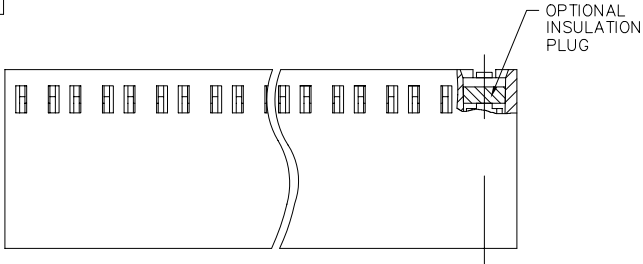

mat'l. code		surface	tolerance	projection	product family
		ISO 1302	ISO 406		PV CARD CONN.
			ISO 1101		
ltr	ecn no	dr	date	tolerances unless otherwise specified	title
H	v32203	MSC	2/9/94	angles linear .xx ±.01/.3	2 X .100
J	v60889	LSS	8/9/96	.xxx ±.005/.13	CARD CONNECTOR
K	v61633	EPK	11/14/96	xxxx ±.0020/.051	dwg no
L	v70994	JM	10/19/97	dr J. SHREINER 3/14/90	sheet 1 of 6 size
M	v02523	AZ	10/24/00	enrg M. HAHN 3/14/90	66924 A3
N	M05-0181	MHT	8/13/05	chr M. HAHN 3/14/90	type Product Customer Drawing
P	M06-0117	M.N.	06/01/06	appd M. HAHN 3/14/90	
sheet	revision	P	P	P	P
index	sheet	1	2	3	4

PDM: Rev:P STATUS:Released Printed: Dec 12, 2008

PRODUCT NO.
SEE TABLE

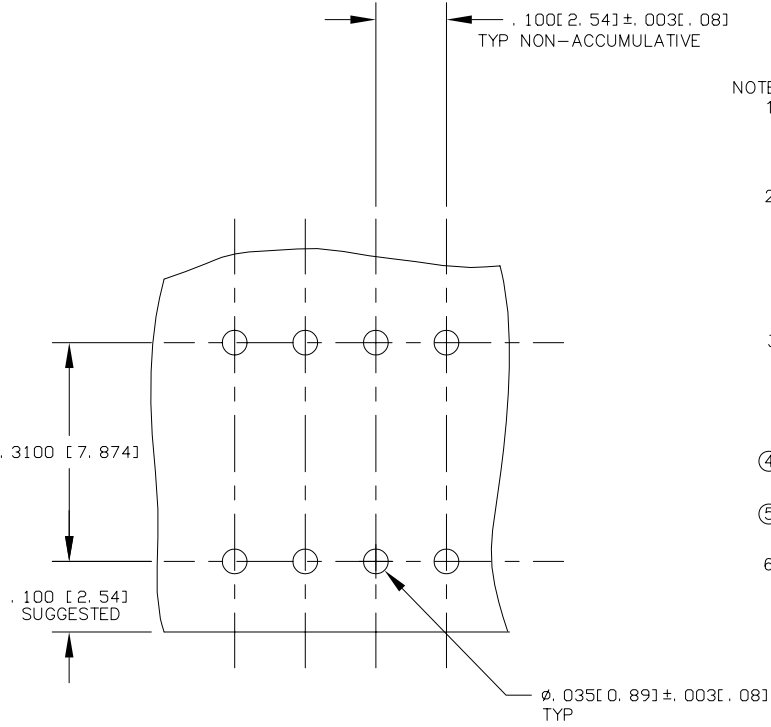

NOTES.

1. HOUSING MATERIAL.
FILLED HIGH TEMPERATURE NYLON
PER UL 94V-0
COLOR: BLACK
2. TERMINAL MATERIAL.
BODY: 1/2 HARD BRASS. ALLOY C26000 .010/.25 THICK.
SPRING: BE-CU. ALLOY C17200 HEAT TREATED
BODY PLATING:
15 MICROINCH/.38 MICRON GOLD OVER 50 MICROINCH
1.27 MICRON IN CONTACT AREA.
SPRING PLATING: GOLD FLASH
3. APPLICATION INFORMATION.
A. RECOMMENDED MOUNTING HOLE PATTERN IS SHOWN IN FIG. "4"
B. ALL MATING PINS TO BE .025/.64 SQUARE ON TRUE CENTER OF GIVEN TERMINAL SPACINGS WITHIN .015/.38 DIA.
C. SUGGESTED MATING PIN LENGTH .350±.020/8.89±.51.
- ④ ADD "LF" SUFFIX AT THE END OF PART NUMBER FOR LEAD FREE OPTION.
- ⑤ THESE PRODUCT MEETS EUROPEAN UNION DIRECTIVES AND OTHER COUNTRY REGULATIONS AS DESCRIBED IN GS-22-008
6. THIS PART WILL WITHSTAND EXPOSURE TO 260°C PEAK TEMPERATURE FOR 20 SECONDS IN A WAVE SOLDER, INFRA-RED OR VAPOR PHASE SOLDER PROCESS.

FIGURE 1
SCALE 10/1

mat'l. code		surface ISO 1302	tolerance ISO 406 ISO 1101	projection	product family PV CARD CONN.
ltr	ecn no	dr	date	angles	linear
P				0°±2°	linear
		tolerances unless otherwise specified		title	
		.xx ±.01/.3		2 X .100	
		.xxx ±.005/.13		CARD CONNECTOR	
		.xxxx ±.0020/.051		scale 4:1	
		dr J. SHREINER 3/14/90		FCJ	
		enrg M. HAHN 3/14/90		sheet 2 of 6 size	
		chr M. HAHN 3/14/90		66924 A3	
		appd M. HAHN 3/14/90		type Product Customer Drawing	
sheet index	revision sheet				

PRODUCT NUMBER	N. OF POS.	DIM. A	DIM. B	INSULATION PLUG	LEAD FREE OPTION
66924-001	2X1	.00/0	.120/3.05	NO	NOTE 5,6
-002	2X2	.10/2.5	.220/5.59		
-003	2X3	.20/5.0	.320/8.13		
-004	2X4	.30/7.6	.420/10.67		
-005	2X5	.40/10.1	.520/13.21		
-006	2X6	.50/12.7	.620/15.75		
-007	2X7	.60/15.2	.720/18.27		
-008	2X8	.70/17.7	.820/20.83		
-009	2X9	.80/20.3	.920/23.37		
-010	2X10	.90/22.8	1.020/25.91		
-011	2X11	1.00/25.4	1.120/28.45		
-012	2X12	1.10/27.9	1.220/30.99		
-013	2X13	1.20/30.4	1.320/33.53		
-014	2X14	1.30/33.0	1.420/36.07		
-015	2X15	1.40/35.5	1.520/38.61		
-016	2X16	1.50/38.1	1.620/41.15		
-017	2X17	1.60/40.6	1.720/43.69		
-018	2X18	1.70/43.1	1.820/46.23		
-019	2X19	1.80/45.7	1.920/48.77		
-020	2X20	1.90/48.2	2.020/51.31		
-021	2X21	2.00/50.8	2.120/53.85		
-022	2X22	2.10/53.3	2.220/56.39		
-023	2X23	2.20/55.8	2.320/58.93		
-024	2X24	2.30/58.4	2.420/61.47		
-025	2X25	2.40/60.9	2.520/64.01		
-026	2X26	2.50/63.5	2.620/66.55		
-027	2X27	2.60/66.0	2.720/69.09		
-028	2X28	2.70/68.5	2.820/71.63		
-029	2X29	2.80/71.1	2.920/74.17		
-030	2X30	2.90/73.6	3.020/76.71		
-031	2X31	3.00/76.2	3.120/79.25		
-032	2X32	3.10/78.7	3.220/81.79		
-033	2X33	3.20/81.2	3.320/84.33		
-034	2X34	3.30/83.8	3.420/86.87		
-035	2X35	3.40/86.3	3.520/89.41		
-036	2X36	3.50/88.9	3.620/91.95		
-037	2X37	3.60/91.4	3.720/94.49		
-038	2X38	3.70/93.9	3.820/97.03		
-039	2X39	3.80/96.5	3.920/99.57		
66924-040	2X40	3.90/99.0	4.020/102.11	NO	NOTE 5,6

mat'l. code	surface ISO 1302	tolerance ISO 406 ISO 1101	projection	product family PV CARD CONN.
ltr ecn no dr date	tolerances unless otherwise specified			title
P	angles	linear	INCH/MM	2 X .100 CARD CONNECTOR
	0°±2'		scale 4:1	dwg no 66924 sheet 3 of 6 size A3
	dr J. SHREINER 3/14/90	enrg M. HAHN 3/14/90		type Product Customer Drawing
	chr M. HAHN 3/14/90	appd M. HAHN 3/14/90		
sheet index	revision sheet			

PDM: Rev:P STATUS:Released Printed: Dec 12, 2008

PRODUCT NO.	N. OF POS.	DIM. A	DIM. B	INSULATION PLUG	LEAD FREE OPTION
66924-041	2X41	4.00/101.6	4.120/104.65	NO	NOTE 5,6
-042	2X42	4.10/104.1	4.220/107.19		
-043	2X43	4.20/106.6	4.320/109.73		
-044	2X44	4.30/109.2	4.420/112.27		
-045	2X45	4.40/111.7	4.520/114.81		
-046	2X46	4.50/114.3	4.620/117.35		
-047	2X47	4.60/116.8	4.720/119.89		
-048	2X48	4.70/119.3	4.820/122.43		
-049	2X49	4.80/121.9	4.920/124.97		
-050	2X50	4.90/124.4	5.020/127.51		
-051	2X51	5.00/127.0	5.120/130.05		
-052	2X52	5.10/129.5	5.220/132.59		
-053	2X53	5.20/132.0	5.320/135.15		
-054	2X54	5.30/134.6	5.420/137.67		
-055	2X55	5.40/137.1	5.520/140.21		
-056	2X56	5.50/139.7	5.620/142.76		
-057	2X57	5.60/142.2	5.720/145.29		
-058	2X58	5.70/144.7	5.820/147.83		
-059	2X59	5.80/147.3	5.920/150.37		
-060	2X60	5.90/149.8	6.020/152.91		
-061	2X61	6.00/152.4	6.120/155.45		
-062	2X62	6.10/154.9	6.220/157.99		
-063	2X63	6.20/157.4	6.320/160.53		
-064	2X64	6.30/160.0	6.420/163.07		
66924-065	2X65	6.40/162.5	6.520/165.61	NO	NOTE 5,6
-066 THRU -100					

OBSOLETE

mat'l. code	surface ISO 1302	tolerance ISO 406 ISO 1101	projection	product family PV CARD CONN.
ltr ecn no dr date	tolerances unless otherwise specified		INCH/MM	title 2 X .100 CARD CONNECTOR
P	angles	linear	scale 4:1	dwg no 66924
	0°±2'			sheet 4 of 6 size A3
	dr J. SHREINER 3/14/90	enrg M. HAHN 3/14/90		type Product Customer Drawing
	chr M. HAHN 3/14/90	appd M. HAHN 3/14/90		
sheet index	revision sheet			

PDM: Rev:P STATUS:Released Printed: Dec 12, 2008

PRODUCT NO.	N. OF POS.	DIM. A	DIM. B	INSULATION PLUG	LEAD FREE OPTION	
66924-501	2X1	.00/0	.120/3.05	YES	NOTE 5,6	UNASSIGNED
-502	2X2	.10/2.5	.220/5.59			UNASSIGNED
-503	2X3	.20/5.0	.320/8.13			
-504	2X4	.30/7.6	.420/10.67			
-505	2X5	.40/10.1	.520/13.21			
-506	2X6	.50/12.7	.620/15.75			
-507	2X7	.60/15.2	.720/18.27			
-508	2X8	.70/17.7	.820/20.83			
-509	2X9	.80/20.3	.920/23.37			
-510	2X10	.90/22.8	1.020/25.91			
-511	2X11	1.00/25.4	1.120/28.45			
-512	2X12	1.10/27.9	1.220/30.99			
-513	2X13	1.20/30.4	1.320/33.53			
-514	2X14	1.30/33.0	1.420/36.07			
-515	2X15	1.40/35.5	1.520/38.61			
-516	2X16	1.50/38.1	1.620/41.15			
-517	2X17	1.60/40.6	1.720/43.69			
-518	2X18	1.70/43.1	1.820/46.23			
-519	2X19	1.80/45.7	1.920/48.77			
-520	2X20	1.90/48.2	2.020/51.31			
-521	2X21	2.00/50.8	2.120/53.85			
-522	2X22	2.10/53.3	2.220/56.39			
-523	2X23	2.20/55.8	2.320/58.93			
-524	2X24	2.30/58.4	2.420/61.47			
-525	2X25	2.40/60.9	2.520/64.01			
-526	2X26	2.50/63.5	2.620/66.55			
-527	2X27	2.60/66.0	2.720/69.09			
-528	2X28	2.70/68.5	2.820/71.63			
-529	2X29	2.80/71.1	2.920/74.17			
-530	2X30	2.90/73.6	3.020/76.71			
-531	2X31	3.00/76.2	3.120/79.25			
-532	2X32	3.10/78.7	3.220/81.79			
-533	2X33	3.20/81.2	3.320/84.33			
-534	2X34	3.30/83.8	3.420/86.87			
-535	2X35	3.40/86.3	3.520/89.41			
-536	2X36	3.50/88.9	3.620/91.95			
-537	2X37	3.60/91.4	3.720/94.49			
-538	2X38	3.70/93.9	3.820/97.03			
-539	2X39	3.80/96.5	3.920/99.57			
66924-540	2X40	3.90/99.0	4.020/102.11	YES	NOTE 5,6	

mat'l. code	surface ISO 1302	tolerance ISO 406 ISO 1101	projection	product family PV CARD CONN.
ltr ecn no dr date	tolerances unless otherwise specified	angles linear	INCH/MM	title 2 X .100 CARD CONNECTOR
	0°±2'	dr J. SHREINER 3/14/90	scale 4:1	dwg no 66924 sheet 5 of 6 size A3
	enrg M. HAHN 3/14/90	chr M. HAHN 3/14/90		type Product Customer Drawing
sheet index	revision sheet	appd M. HAHN 3/14/90		

PDM: Rev:P STATUS:Released Printed: Dec 12, 2008

PRODUCT NO.	N. OF POS.	DIM. A	DIM. B	INSULATION PLUG	LEAD FREE OPTION
66924-541	2X41	4.00/101.6	4.120/104.65	YES	NOTE 5,6
-542	2X42	4.10/104.1	4.220/107.19		
-543	2X43	4.20/106.6	4.320/109.73		
-544	2X44	4.30/109.2	4.420/112.27		
-545	2X45	4.40/111.7	4.520/114.81		
-546	2X46	4.50/114.3	4.620/117.35		
-547	2X47	4.60/116.8	4.720/119.89		
-548	2X48	4.70/119.3	4.820/122.43		
-549	2X49	4.80/121.9	4.920/124.97		
-550	2X50	4.90/124.4	5.020/127.51		
-551	2X51	5.00/127.0	5.120/130.05		
-552	2X52	5.10/129.5	5.220/132.59		
-553	2X53	5.20/132.0	5.320/135.15		
-554	2X54	5.30/134.6	5.420/137.67		
-555	2X55	5.40/137.1	5.520/140.21		
-556	2X56	5.50/139.7	5.620/142.76		
-557	2X57	5.60/142.2	5.720/145.29		
-558	2X58	5.70/144.7	5.820/147.83		
-559	2X59	5.80/147.3	5.920/150.37		
-560	2X60	5.90/149.8	6.020/152.91		
-561	2X61	6.00/152.4	6.120/155.45		
-562	2X62	6.10/154.9	6.220/157.99		
-563	2X63	6.20/157.4	6.320/160.53		
-564	2X64	6.30/160.0	6.420/163.07		
66924-565	2X65	6.40/162.5	6.520/165.61	YES	
-566 THRU					OBSOLETE
-600					
66924-801					NOTE 5,6 OBSOLETE

mat'l. code	surface	tolerance	projection	product family
	ISO 1302	ISO 406		PV CARD CONN.
itr	ecn	no	dr	date
P				
tolerances unless otherwise specified		linear	INCH/MM	title
angles	0°±2'	linear	scale 4:1	2 X .100 CARD CONNECTOR
dr	J. SHREINER	3/14/90		dwg no
enrg	M. HAHN	3/14/90		66924
chr	M. HAHN	3/14/90		sheet 6 of 6 size
appd	M. HAHN	3/14/90		A3
sheet	revision			type
index	sheet			Product Customer Drawing

PDM: Rev:P STATUS:Released Printed: Dec 12, 2008