

Customer Information Sheet

DRAWING No.: M7580/81/82/83-XX SHEET 2 OF 2 IF IN DOUBT - ASK © NOT TO SCALE THIRD ANGLE PROJECTION ALL DIMENSIONS IN mm

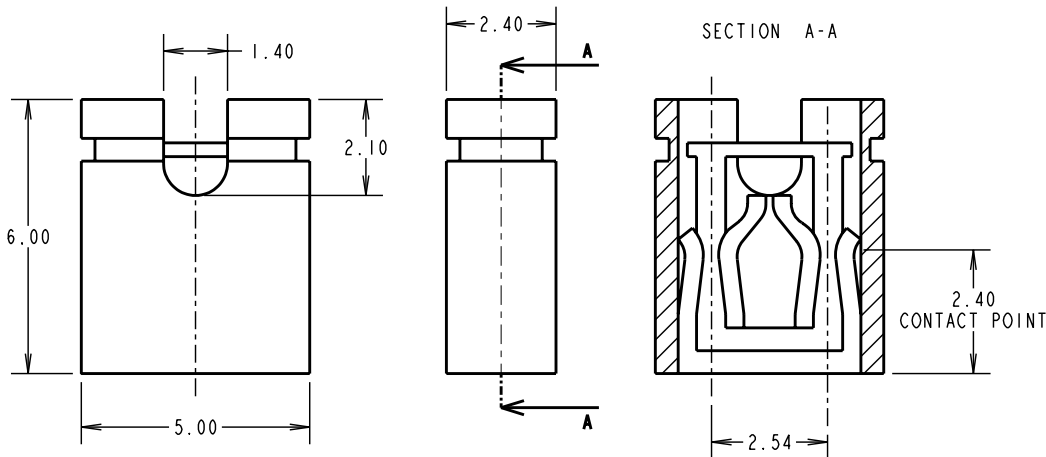

SPECIFICATION.

MATERIAL:

INSULATOR = 30% GLASS FILLED PBT UL94V-0
(SEE ORDER CODE FOR COLOUR)

CONTACT = PHOSPHOR BRONZE

FINISH:

05 = SELECTIVE GOLD OVER NICKEL

46 = 100% TIN

ELECTRICAL:

CURRENT RATING = 1A

INSULATION RESISTANCE = 5,000 MEGOHMS MIN

CONTACT RESISTANCE = 20 MILLIOHMS MAX

DIELECTRIC STRENGTH = 500V AC

MECHANICAL:

INSERTION FORCE = 13.7N MAX, 2.0N MIN

WITHDRAWAL FORCE = 7.4N MAX, 1.0N MIN

ENVIRONMENTAL:

OPERATING TEMPERATURE = -55°C TO +105°C

- NOTES:
1. RECOMMENDED PIN SIZE = 0.64mm SQUARE.
2. ALL TOLERANCES ± 0.20 mm UNLESS OTHERWISE STATED.

ORDER CODE:

M75XX-XX

MOULDING COLOUR

80 = GREY

81 = RED

82 = BLACK

83 = BLUE

CONTACT FINISH

05 = GOLD

46 = 100% TIN

CP	7	23.12.09	10620
NAME	ISS.	DATE	C/NOTE
APPROVED: C.PENROSE			
CHECKED: R.ADE			
DRAWN: A. G. LIOTTA			
CUSTOMER REF.:			
ASSEMBLY DRG:			

HARWIN

HARWIN USA
TEL: 603 893 5376
FAX: 603 893 5396
mis@harwin.com

HARWIN Europe (UK)
TEL: 023 9231 4545
FAX: 023 9231 4590
mis@harwin.co.uk

HARWIN Asia
TEL: +65 6 779 4909
FAX: +65 6 779 3868
mis@harwin.com.sg

THIS DRAWING AND ANY INFORMATION OR DESCRIPTIVE MATTER SET OUT HEREON ARE CONFIDENTIAL AND COPYRIGHT PROPERTY OF THE HARWIN GROUP AND MUST NOT BE DISCLOSED, LOANED, COPIED OR USED FOR MANUFACTURING, TENDERING OR FOR ANY OTHER PURPOSE WITHOUT THEIR WRITTEN PERMISSION.

TOLERANCES

X. = ± 1 mm

X.X = ± 0.25 mm

X.XX = ± 0.10 mm

X.XXX = ± 0.01 mm

ANGLES = $\pm 5^\circ$

UNLESS STATED

MATERIAL:

SEE ABOVE

FINISH:

SEE ABOVE

S/AREA:

mm²

TITLE:

SINGLE OPERATION
2.54mm PITCH OPEN TOP
JUMPER SOCKET

DRAWING NUMBER:

M7580/81/82/83-XX

SHT

2 OF 2