



Series 501 Standard DIP Sockets with Wire Wrap Bifurcated Contacts

FEATURES:

- Standard DIP Sockets are available with solder tail or wire wrap pins, all with bifurcated contacts. Consult Data Sheet No. 12004 for solder tail pins.
- Aries offers these standard DIP sockets in more sizes than any other manufacturer.

SPECIFICATIONS:

- Standard body material is black UL 94 V-0 Glass-filled 4/6 Nylon.
- Bifurcated contacts are Grade A spring-tempered Phosphor Bronze per QQ-B-750.
- Pin plating is:
 - 1 = 10 μ " [25 μ m] min. Gold per MIL-G-45204 over 50 μ " [1.27 μ m] min. Nickel per SAE-AMS-QQ-N-290.
 - 0 = 200 μ " min Matte Tin per ASTM B545-97 over 50 μ " min Nickel per SAE-AMS-QQ-N-290.
 - OTL = 200 μ " min. 90/10 Tin/Lead per MIL-T-10727 Type 1 over 50 μ " min. Nickel per SAE-AMS-QQ-N-290.
- Contact current rating=1.5 Amps.
- Insertion Force=110 grams/pin average; Withdrawal Force=75 grams/pin average.
- Operating Temp. =-67°F to 221°F [-55°C to 105°C] Tin =-67°F to 257°F [-55°C to 125°C] Gold
- Accepts flat leads up to .014 thk. x .020 wide [.36-.51], round leads up to .020 [.51] in diameter.
- Socket accepts lead lengths from seating plane from .075-.160 [1.91-4.06].

MOUNTING CONSIDERATIONS:

- Suggested PCB hole size=.045 \pm .002 [1.12 \pm .05]. dia.

ALL DIMENSIONS: INCHES [MILLIMETERS]

All tolerances \pm .005 [.13] unless otherwise specified

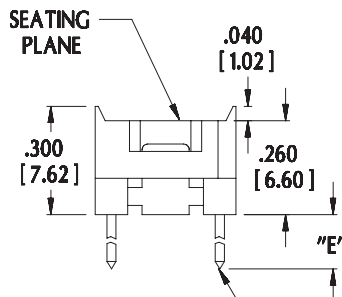
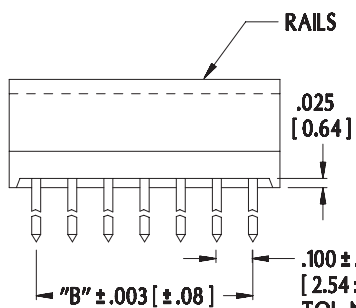
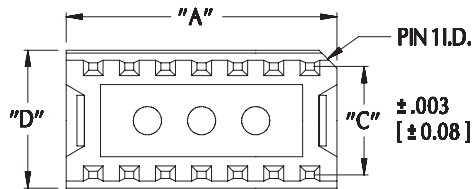

Consult Data Sheet No. 12004 for standard DIP sockets with solder tail bifurcated contacts.

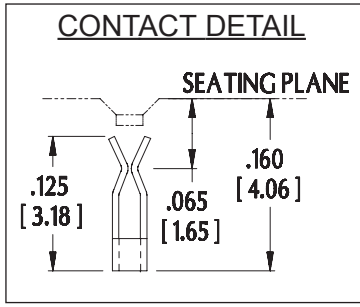

Wire wrap	Length "E"
2 level	.410 [10.41]
3 level	.690 [17.52]

"A"=(NO. OF PINS PER ROW X .100 [2.54]) + .050 [1.27]
 "B"=(NO. OF PINS PER ROW - 1) X .100 [2.54]

.025 \pm .002 SQUARE
 [.64 \pm .05]

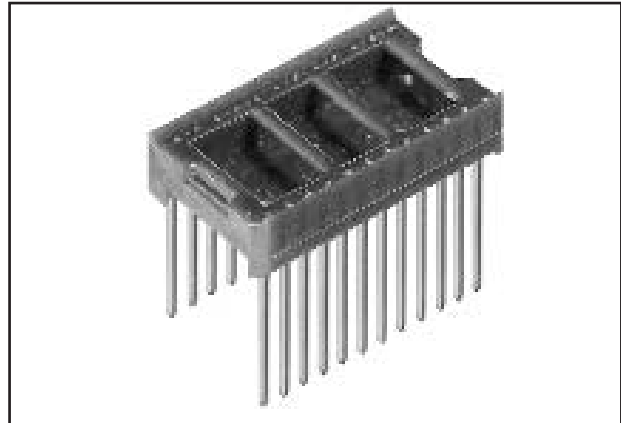

Note: Aries specializes in custom design and production. In addition to the standard products shown on this page, special materials, platings, sizes, and configurations can be furnished, depending on quantities. Aries reserves the right to change product specifications without notice.

ORDERING INFORMATION

XX - X501 - XXXXXX

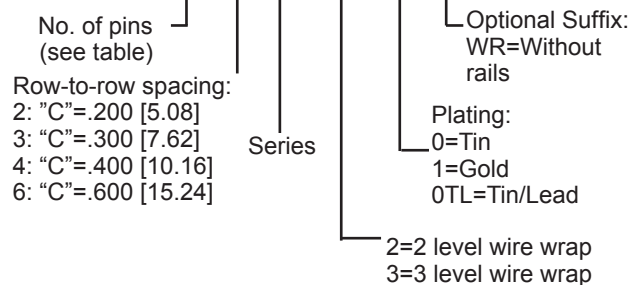

Centers "C"	Width "D"	Available Sizes
.200 [5.08]	.290 [7.36]	8, 10
.300 [7.62]	.390 [9.90]	8, 14-20
.400 [10.16]	.490 [12.45]	22
.600 [15.24]	.690 [17.54]	8-24, 28-40, 48



Bristol, PA USA
 TEL: (215) 781-9956
 FAX: (215) 781-9845



12005
 REV. D