

Customer Information Sheet

DRAWING No.: M7765/66/67/71-XX SHEET 2 OF 2 IF IN DOUBT - ASK © NOT TO SCALE THIRD ANGLE PROJECTION ALL DIMENSIONS IN mm

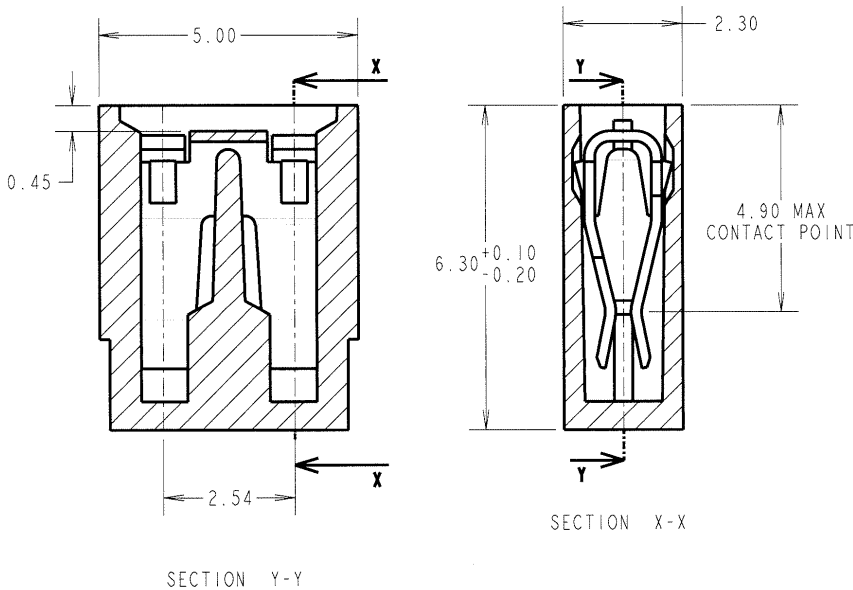

SPECIFICATIONS:
MATERIAL:
 MOULDING = GLASS FILLED POLYESTER UL94V-0 (SEE ORDER CODE FOR COLOUR)
 CLIP = PHOSPHOR BRONZE
FINISH:
 05 = 0.13µ GOLD
 06 = 3µ 90/10 TIN/LEAD
 46 = 3µ 100% TIN
ELECTRICAL:
 CURRENT RATING = 3A MAX
 VOLTAGE RATING = 250V AC/DC
 VOLTAGE PROOF = 750V AC
 CONTACT RESISTANCE = 30mΩ MAX (TIN), 25mΩ MAX (GOLD)
 INSULATION RESISTANCE = 1,000MΩ MIN
MECHANICAL:
 DURABILITY = 50 OPERATIONS (TIN), 300 OPERATIONS (GOLD)
 INSERTION FORCE = 12.5N MAX
 WITHDRAWAL FORCE = 1.0N MIN
ENVIRONMENTAL:
 TEMPERATURE RANGE = -40°C TO +85°C
PACKING:
 BAG

NOTES:
 1. MATING PIN = 0.64mm SQUARE,
 2. FOR COMPLETE SPECIFICATIONS, SEE COMPONENT SPECIFICATION C003XX (LATEST ISSUE).

ORDER CODE: **M77XX-XX**

MOULDING COLOUR

65 - LT. GREY	66 - RED
67 - BLACK	71 - BLUE

CONTACT FINISH

05 - GOLD
06 - TIN
46 - 100% TIN

JAE	7	21.02.05	8402
NAME	ISS.	DATE	C/NOTE
APPROVED: <i>[Signature]</i>			
CHECKED: <i>[Signature]</i>			
DRAWN: J. CLAY			
CUSTOMER REF.:			
ASSEMBLY DRG:			

HARWIN

HARWIN INC U.S.A. TEL: (812) 542 2540 FAX: (812) 542 2541	HARWIN PLC U.K. TEL: 023 9231 4545 FAX: 023 9231 4590	HARWIN PTE SINGAPORE TEL: 65 6779 4909 FAX: 65 6779 3868
--	--	---

THIS DRAWING AND ANY INFORMATION OR DESCRIPTIVE MATTER SET OUT HEREON ARE CONFIDENTIAL AND COPYRIGHT PROPERTY OF THE HARWIN GROUP AND MUST NOT BE DISCLOSED, LOANED, COPIED OR USED FOR MANUFACTURING, TENDERING OR FOR ANY OTHER PURPOSE WITHOUT THEIR WRITTEN PERMISSION.

TOLERANCES
 X. = ±1mm
 X.X = ±0.25mm
 X.XX = ±0.10mm
 X.XXX = ±0.01mm
 ANGLES = ±5°
 UNLESS STATED

MATERIAL: SEE ABOVE
FINISH: SEE ABOVE
S/AREA: mm²

TITLE: CLOSED TOP JUMPER SOCKET
DRAWING NUMBER:
M7765-XX **M7767-XX**
M7766-XX **M7771-XX**

SHT 2 OF 2