

Recommended PCB Layout (Top View)

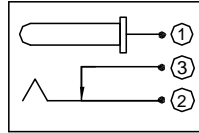
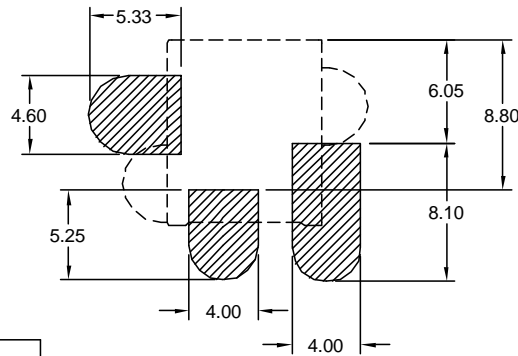

Schematic

Electrical Characteristics

Contact Resistance
 Before Test
 Between Terminals: 30 milliohms Max.
 Plug to Contacts: 50 milliohms Max.
 After Test:
 Between Terminals: 60 milliohms Max.
 Plug to Contacts: 100 milliohms Max.
 Rated Voltage: 16V DC
 Rated Current: 3.5 Amps
 Insulation Resistance: 100 Megohms Min.
 at 500V DC
 Dielectric Withstanding Voltage:
 500V AC for 1 minute

Mechanical Characteristics

Durability Test: 5000 cycles
 Insertion Force: 0.3kg-3.0kg
 Extraction Force: 0.3kg-3.0kg
 Operating Temp: -25°C to +85°C

Material and Finish

Main Housing: LCP
 Bottom Cover: PA9T
 UL94V-0, Color: Black
 Center Pin: Copper, Nickel Plated
 Contact #1: Brass, Silver Plated
 Contact #2: Phosphor Bronze, Silver Plated
 Contact #3: Brass, Silver Plated

Tolerances	
X.X	± 0.2
X.XX	± 0.1
Angles	± 2°
Unless Specified Otherwise	

Part Number	Center Post Diameter	Packaging
KLDV-SMT-02-A-TR	Ø2.00	Tape & Reel (TR option)

CSA NRTL/C Certified File No. LR78160

REVISION	DATE	DESCRIPTION	DRAWN BY	CHECKED BY	UNITS
B5	3/13/02	REF ECO 01-213	K. Wallace	H. MA	mm
B6	12/09/04	ECO #04-065	REVISED BY	CHECK DATE	DATE
B7	10-27/05	ECO #05-061	R. Aguirre	10/27/05	7/9/99

KLDV-SMT-02-A

Power Jack, Vertical SMT

Ø2.0mm Center Pin

