



Heyco® "Female Bridge" Preassembled Cordset Components

NEMA 5-15R

- Crimp all three terminals at once.
- Faster loading of plug molds.
- Automated terminating equipment is available, see page 7-11.
- Reduces plug molding cycle time.
- Assures reliable contact performance.
- Passes UL/CSA cold temperature insertion test.
- Improves plug quality.
- Reduces PVC usage and plug cost!
- Eliminates the need for a polarity barrier.

| PART NO. | DESCRIPTION | WIRE RANGE | DIE | CRIMP PUNCH | ANVIL |
|----------|--------------------------------------|------------|------|-------------|-------|
| S7570 | 5-15R Female Bridge Assembly Black | 18-12 AWG | Z370 | Z335, Z409 | Z334 |
| S7571 | 5-15R Female Bridge Assembly Natural | 18-12 AWG | Z370 | Z335, Z409 | Z334 |
| S7572 | 5-15R Female Bridge Assembly Black | 12-10 AWG | Z641 | Z636, Z637 | Z635 |
| S7573 | 5-15R Female Bridge Assembly Natural | 12-10 AWG | Z641 | Z636, Z637 | Z635 |

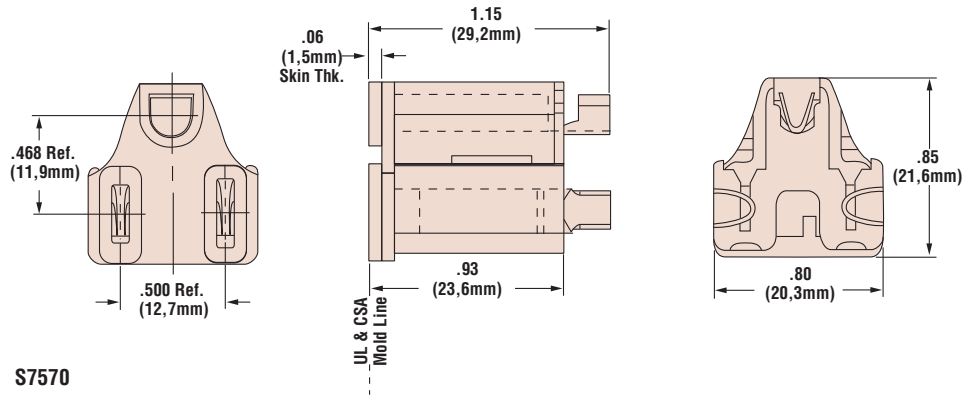

Heyco® IEC 320 Preassembled Cordset Components

- Crimp all three terminals at once.
- Faster loading of plug molds.
- Automated terminating equipment is available. Consult Heyco for details.
- Assures reliable contact performance.
- Improves plug quality.
- Reduces PVC usage and plug cost.
- Available assembled or unassembled.

| PART NO. | DESCRIPTION | WIRE RANGE | DIE | CRIMP PUNCH | ANVIL |
|----------|-------------------------------------|-------------|------------------------|-------------|-------|
| S7580 | IEC 320 Biz. Machine Assembly Black | 18-14 (AWG) | S7580SXX5 | C774 | C775 |
| S7780 | Unassembled IEC-320 Housing Black | — | — | — | — |
| S7200 | Unassembled BMC IEC-320 Contact | 18-14 (AWG) | S7200UXX5 S7200SXX5 | C688 | C689 |

